

2-Phase Stepper Motor Unipolar Driver ICs

Absolute Maximum Ratings

(T_a=25°C)

Parameter	Symbol	Ratings				Units
		SLA7022MU	SLA7029M	SMA7022MU	SMA7029M	
Motor supply voltage	V _{CC}	46				V
FET Drain-Source voltage	V _{DSS}	100				V
Control supply voltage	V _S	46				V
TTL input voltage	V _{IN}	7				V
Reference voltage	V _{REF}	2				V
Output current	I _O	1	1.5	1	1.5	A
Power dissipation	P _{D1}	4.5 (Without Heatsink)		4.0 (Without Heatsink)		W
	P _{D2}	35 (T _C =25°C)		28(T _C =25°C)		W
Channel temperature	T _{ch}	+150				°C
Storage temperature	T _{stg}	-40 to +150				°C

Electrical Characteristics

(T_a=25°C)

Parameter	Symbol	Ratings												Units
		SLA7022MU			SLA7029M			SMA7022MU			SMA7029M			
		min	typ	max	min	typ	max	min	typ	max	min	typ	max	
Control supply current	I _S		10	15		10	15		10	15		10	15	mA
	Condition	V _S =44V			V _S =44V			V _S =44V			V _S =44V			
Control supply voltage	V _S	10	24	44	10	24	44	10	24	44	10	24	44	V
FET Drain-Source voltage	V _{DSS}	100			100			100			100			V
	Condition	V _S =44V, I _{DSS} =250 μA			V _S =44V, I _{DSS} =250 μA			V _S =44V, I _{DSS} =250 μA			V _S =44V, I _{DSS} =250 μA			
FET ON voltage	V _{DS}			0.85			0.6			0.85			0.6	V
	Condition	I _D =1A, V _S =14V			I _D =1A, V _S =14V			I _D =1A, V _S =14V			I _D =1A, V _S =14V			
FET drain leakage current	I _{DSS}			4			4			4			4	mA
	Condition	V _{DSS} =100V, V _S =44V			V _{DSS} =100V, V _S =44V			V _{DSS} =100V, V _S =44V			V _{DSS} =100V, V _S =44V			
FET diode forward voltage	V _{SD}			1.2			1.1			1.2			1.1	V
	Condition	I _D =1A			I _D =1A			I _D =1A			I _D =1A			
TTL input current	I _{IH}			40			40			40			40	μA
	Condition	V _{IH} =2.4V, V _S =44V			V _{IH} =2.4V, V _S =44V			V _{IH} =2.4V, V _S =44V			V _{IH} =2.4V, V _S =44V			
	I _{IL}			-0.8			-0.8			-0.8			-0.8	mA
	Condition	V _{IL} =0.4V, V _S =44V			V _{IL} =0.4V, V _S =44V			V _{IL} =0.4V, V _S =44V			V _{IL} =0.4V, V _S =44V			
TTL input voltage (Active High)	V _{IH}	2			2			2			2			V
	Condition	I _D =1A			I _D =1A			I _D =1A			I _D =1A			
	V _{IL}			0.8			0.8			0.8			0.8	
	Condition	V _{DSS} =100V			V _{DSS} =100V			V _{DSS} =100V			V _{DSS} =100V			
TTL input voltage (Active Low)	V _{IH}	2			2			2			2			V
	Condition	V _{DSS} =100V			V _{DSS} =100V			V _{DSS} =100V			V _{DSS} =100V			
	V _{IL}			0.8			0.8			0.8			0.8	
	Condition	I _D =1A			I _D =1A			I _D =1A			I _D =1A			
Switching time	T _r		0.5			0.5			0.5			0.5		μs
	Condition	V _S =24V, I _D =0.8A			V _S =24V, I _D =1A			V _S =24V, I _D =0.8A			V _S =24V, I _D =1A			
	T _{stg}		0.7			0.7			0.7			0.7		
	Condition	V _S =24V, I _D =0.8A			V _S =24V, I _D =1A			V _S =24V, I _D =0.8A			V _S =24V, I _D =1A			
	T _f		0.1			0.1			0.1			0.1		
Condition	V _S =24V, I _D =0.8A			V _S =24V, I _D =1A			V _S =24V, I _D =0.8A			V _S =24V, I _D =1A				

Internal Block Diagram

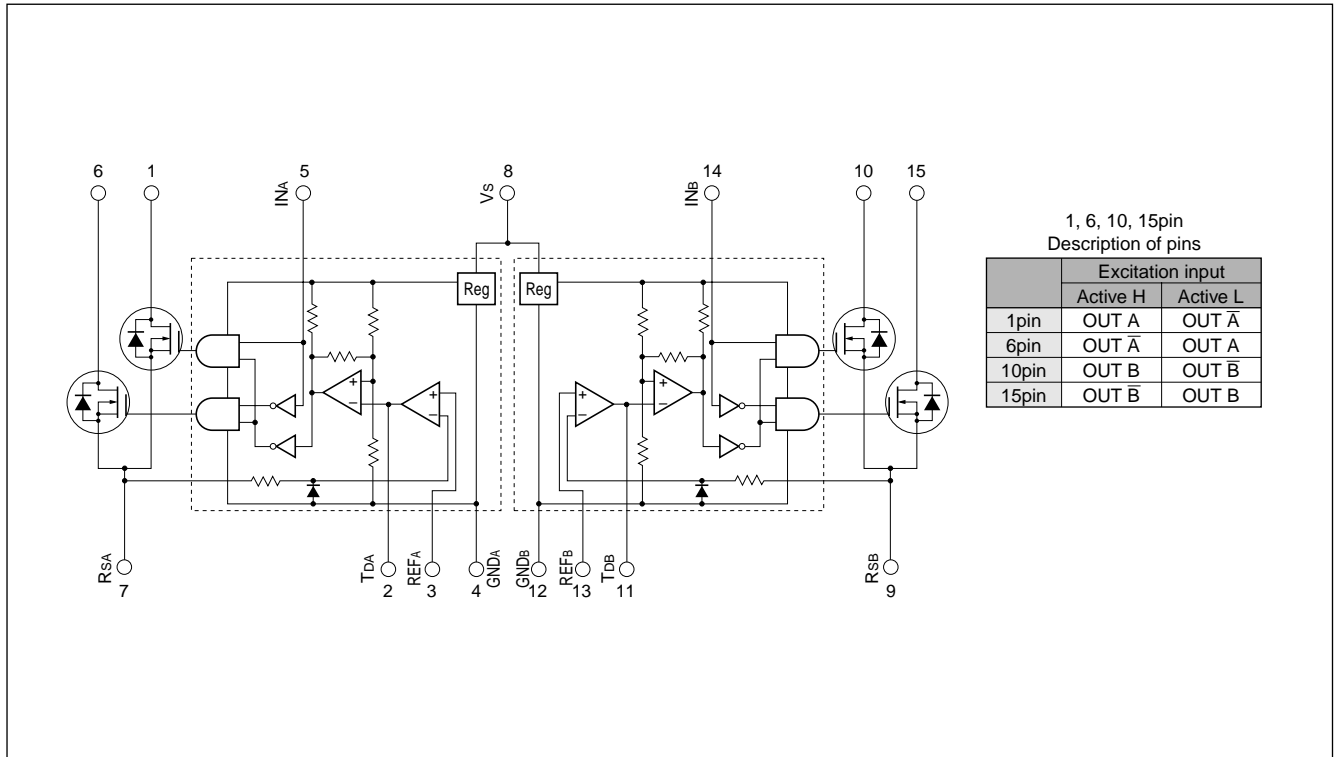
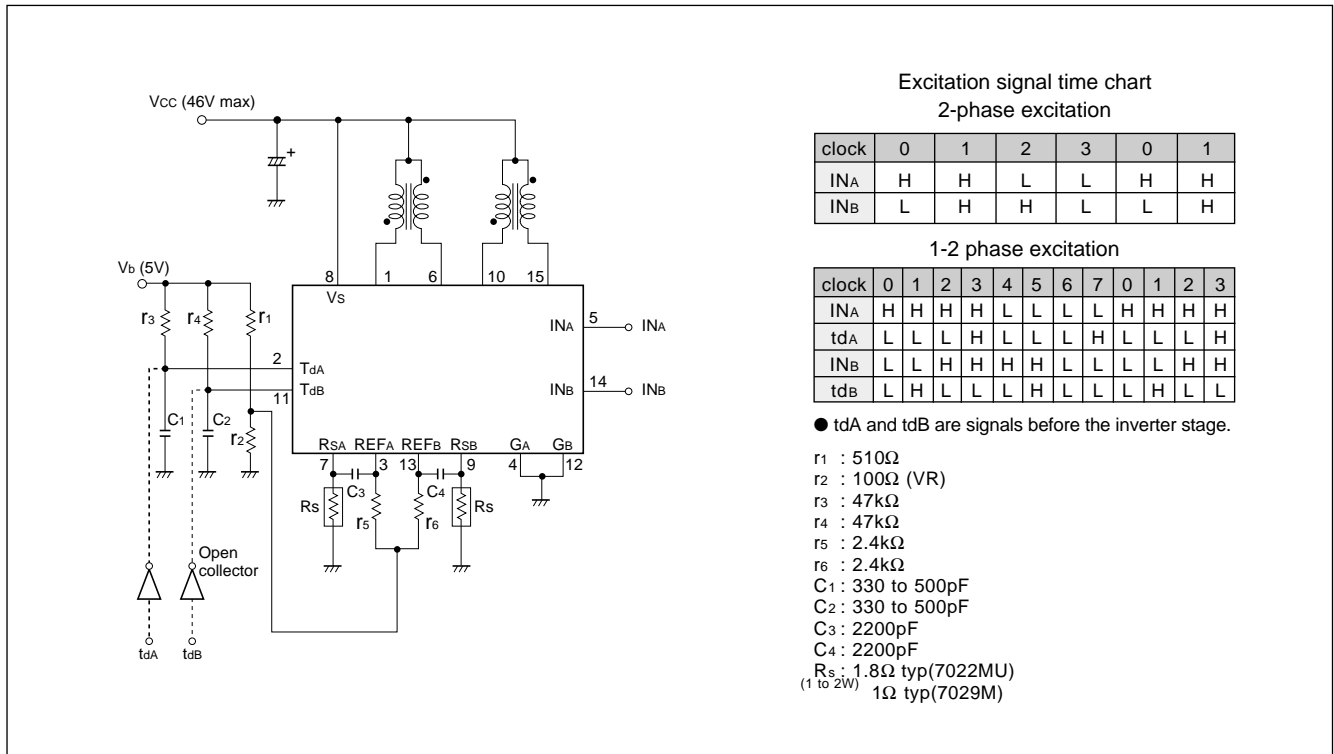
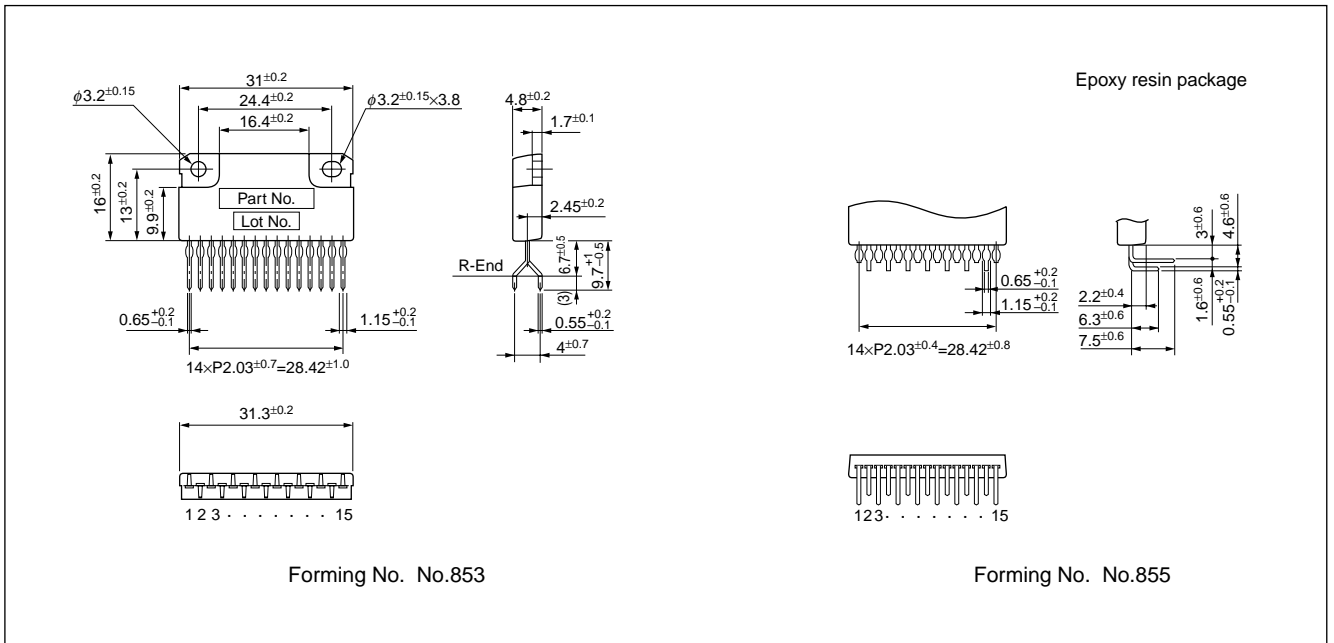

Diagram of Standard External Circuit (Recommended Circuit Constants)



External Dimensions SLA7022MU/SLA7029M

(Unit: mm)



External Dimensions SMA7022MU/SMA7029MA

(Unit: mm)

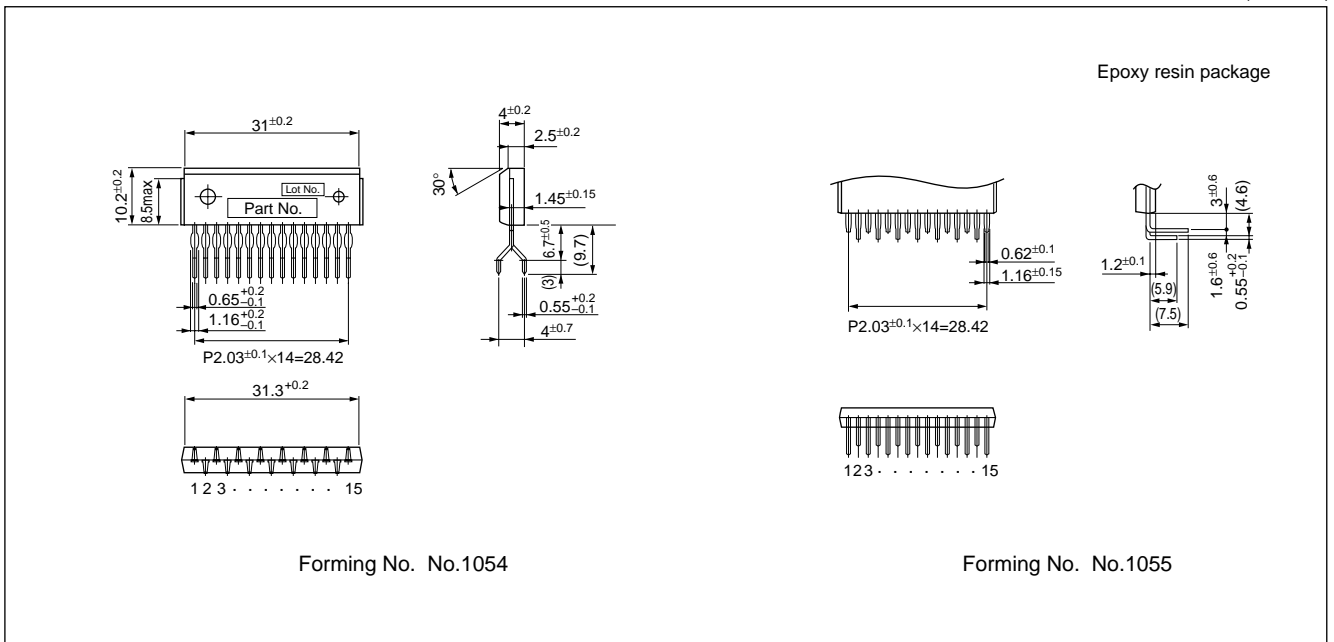

Application Notes

Determining the Output Current

Fig. 1 shows the waveform of the output current (motor coil current). The method of determining the peak value of the output current (I_o) based on this waveform is shown below.

(Parameters for determining the output current I_o)

- V_b : Reference supply voltage
- r_1, r_2 : Voltage-divider resistors for the reference supply voltage
- R_s : Current sense resistor

(1) Normal rotation mode

I_o is determined as follows when current flows at the maximum level during motor rotation. (See Fig.2.)

$$I_o \cong \frac{r_2}{r_1+r_2} \cdot \frac{V_b}{R_s} \dots\dots\dots (1)$$

(2) Power down mode

The circuit in Fig.3 (r_x and T_r) is added in order to decrease the coil current. I_o is then determined as follows.

$$I_{OPD} \cong \frac{1}{1 + \frac{r_1(r_2+r_x)}{r_2 \cdot r_x}} \cdot \frac{V_b}{R_s} \dots\dots\dots (2)$$

Equation (2) can be modified to obtain equation to determine r_x .

$$r_x = \frac{1}{\frac{1}{r_1} \left(\frac{V_b}{R_s \cdot I_{OPD}} - 1 \right) - \frac{1}{r_2}}$$

Fig. 4 and 5 show the graphs of equations (1) and (2) respectively.

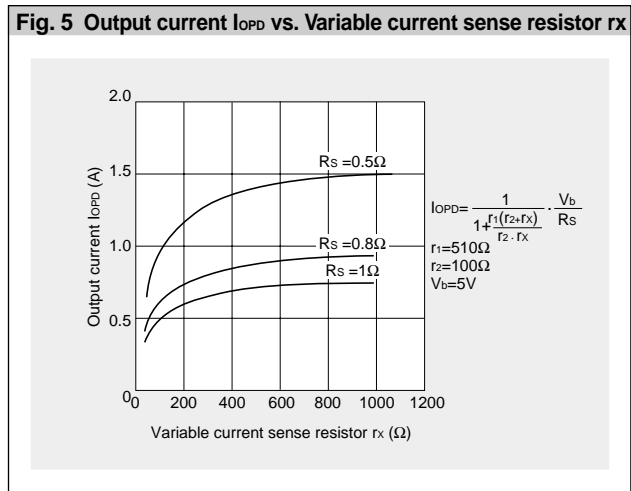
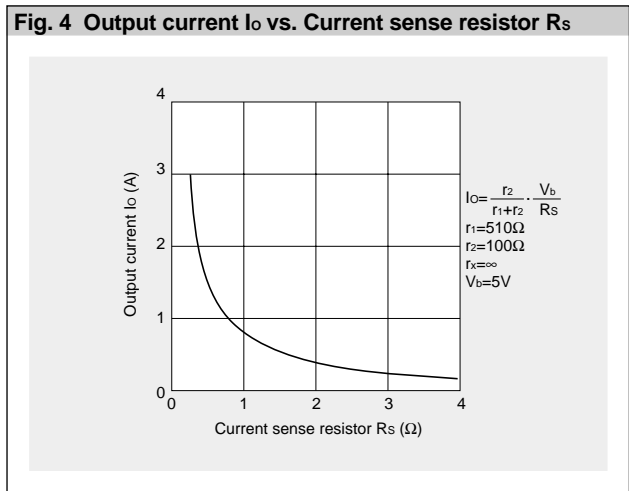
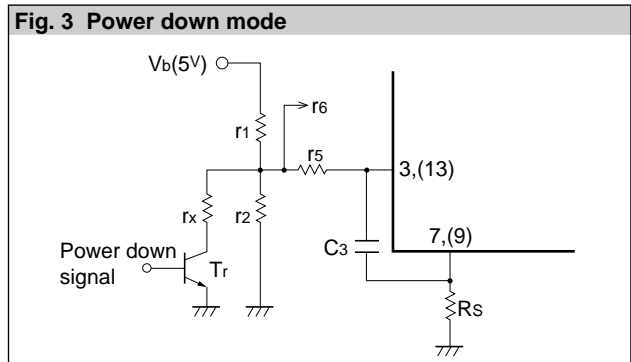
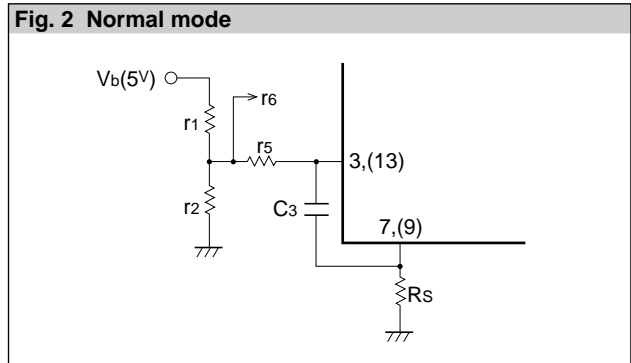
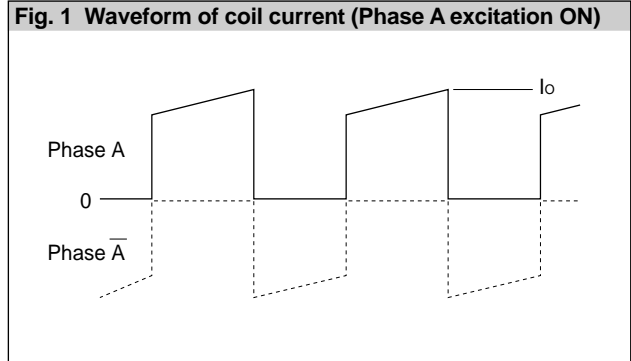

(NOTE)

Ringing noise is produced in the current sense resistor R_s when the MOSFET is switched ON and OFF by chopping. This noise is also generated in feedback signals from R_s which may therefore cause the comparator to malfunction. To prevent chopping malfunctions, $r_5(r_6)$ and $C_3(C_4)$ are added to act as a noise filter.

However, when the values of these constants are increased, the response from R_s to the comparator becomes slow. Hence the value of the output current I_o is somewhat higher than the calculated value.

Determining the chopper frequency

Determining T_{OFF}

The SLA7000M and SMA7000M series are self-excited choppers. The chopping OFF time T_{OFF} is fixed by r₃/C₁ and r₄/C₂ connected to terminal Td.

T_{OFF} can be calculated using the following formula:

$$T_{OFF} \approx -r_3 \cdot C_1 \ln\left(1 - \frac{2}{V_b}\right) = -r_4 \cdot C_2 \ln\left(1 - \frac{2}{V_b}\right)$$

The circuit constants and the T_{OFF} value shown below are recommended.

T_{OFF} = 12μs at r₃=47kΩ, C₁=500pF, V_b=5V

Fig. 6 Chopper frequency vs. Motor coil resistance

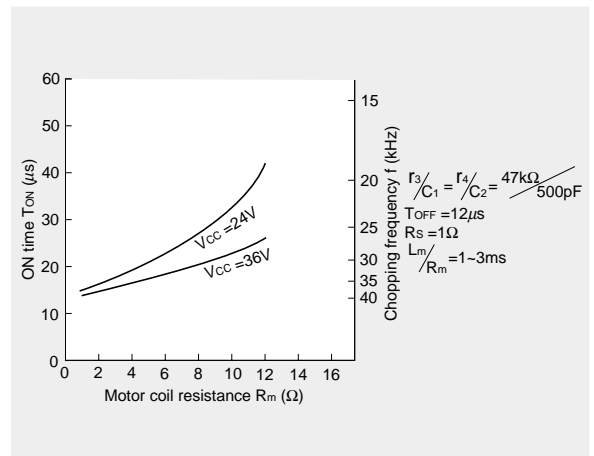

Chopper frequency vs. Supply voltage

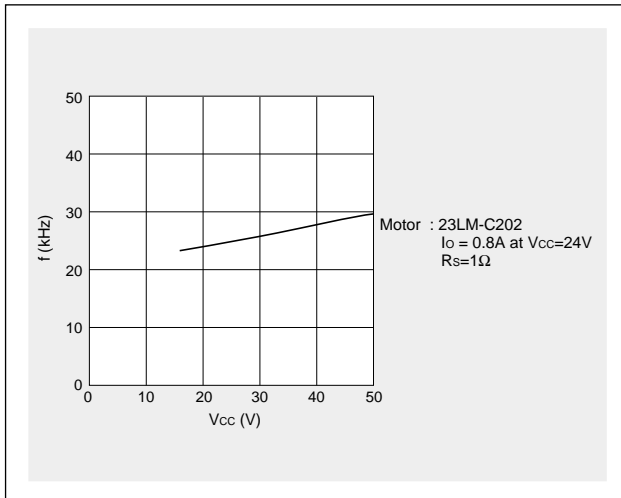

Chopper frequency vs. Output current

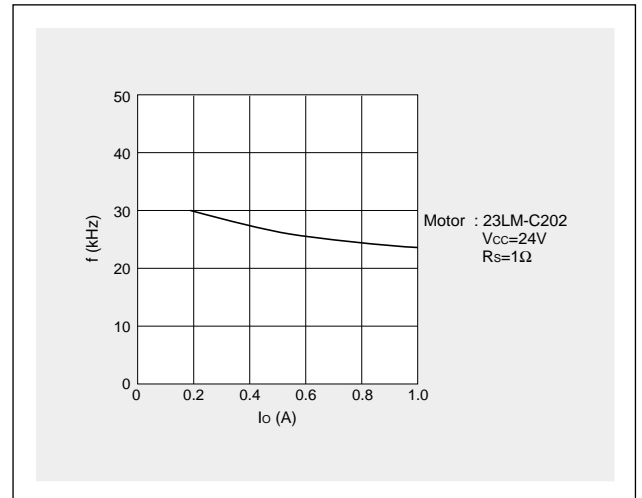

Thermal Design

An outline of the method for calculating heat dissipation is shown below.

(1) Obtain the value of P_H that corresponds to the motor coil current I_o from Fig. 7 "Heat dissipation per phase P_H vs. Output current I_o ."

(2) The power dissipation P_{diss} is obtained using the following formula.

2-phase excitation: $P_{diss} \cong 2P_H + 0.015 \times V_s$ (W)

1-2 phase excitation: $P_{diss} \cong \frac{3}{2} P_H + 0.015 \times V_s$ (W)

(3) Obtain the temperature rise that corresponds to the calculated value of P_{diss} from Fig. 8 "Temperature rise."

Fig. 7 Heat dissipation per phase P_H vs. Output current I_o

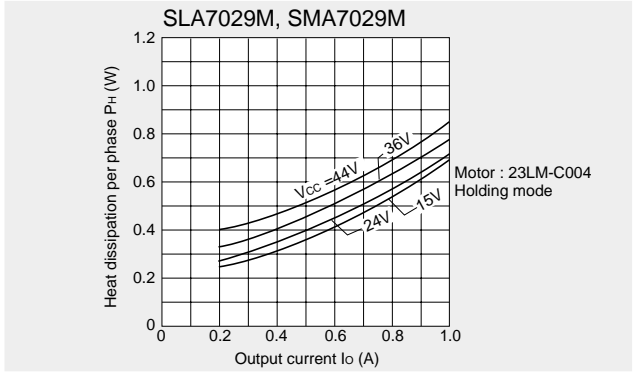
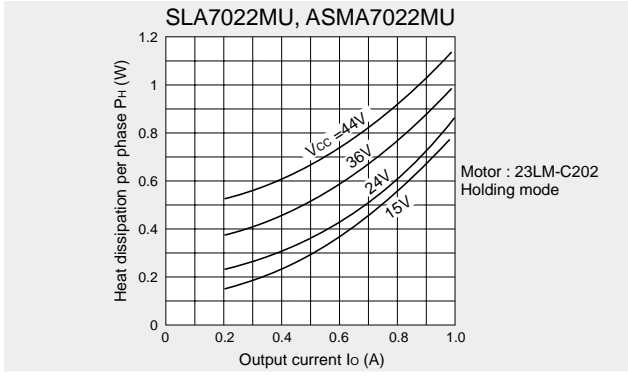
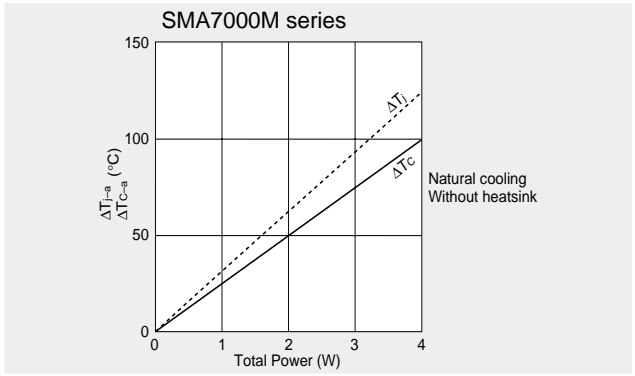
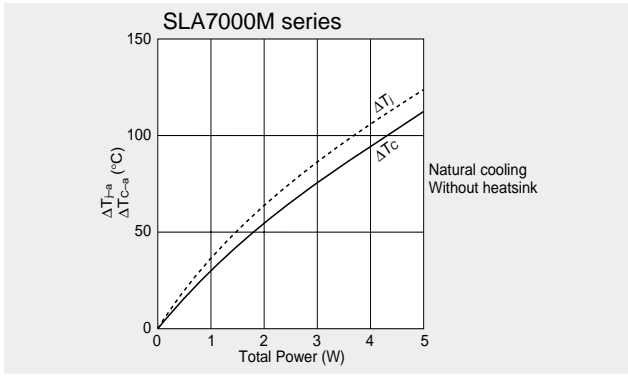
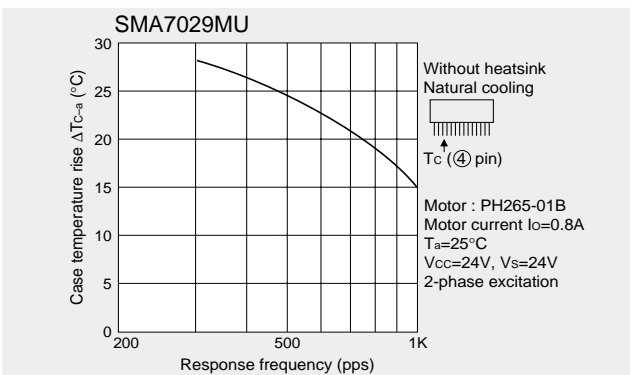
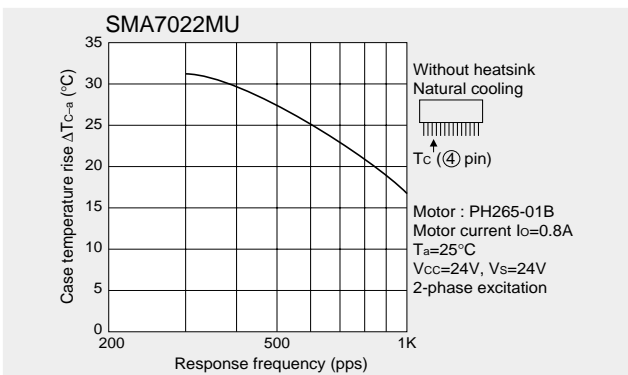
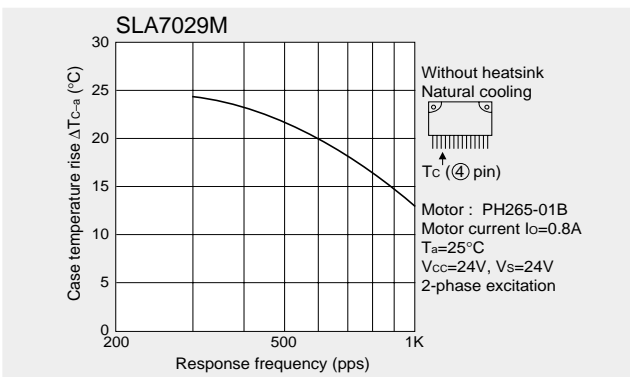
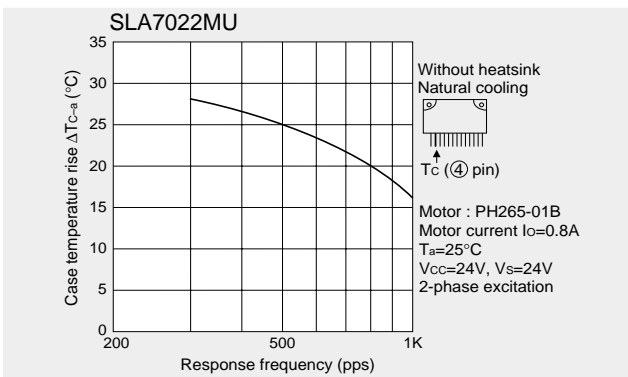

Fig. 8 Temperature rise



Thermal characteristics



■ Supply Voltage V_{CC} vs. Supply Current I_{CC}

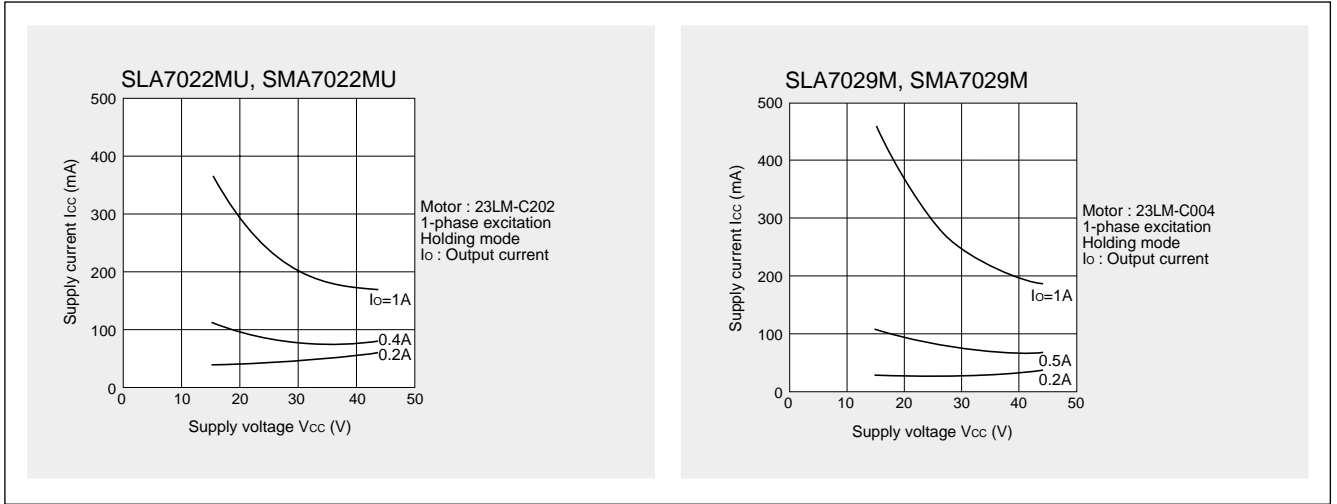

■ Torque Characteristics

