

**OBSOLETE PRODUCT
NO RECOMMENDED REPLACEMENT**
contact our Technical Support Center at
1-888-INTERSIL or www.intersil.com/tsc

**BiMOS Dual Voltage Comparators
with MOSFET Input, Bipolar Output**

The CA3290A and CA3290 types consist of a dual voltage comparator on a single monolithic chip. The common mode input voltage range includes ground even when operated from a single supply. The low supply current drain makes these comparators suitable for battery operation; their extremely low input currents allow their use in applications that employ sensors with extremely high source impedances. Package options are shown in the table below.

Pinout

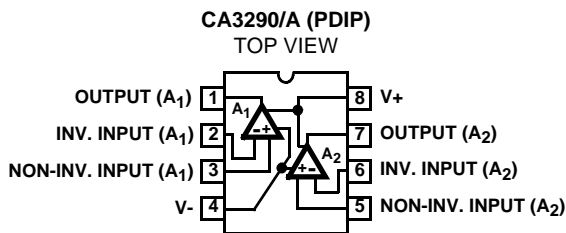

Features

- MOSFET Input Stage
 - Very High Input Impedance (Z_{IN}) 1.7T Ω (Typ)
 - Very Low Input Current at $V_+ = 5V$ 3.5pA (Typ)
 - Wide Common Mode Input Voltage Range (V_{ICR}) Can Be Swung 1.5V (Typ) Below Negative Supply Voltage Rail
 - Virtually Eliminates Errors Due to Flow of Input Currents
- Output Voltage Compatible with TTL, DTL, ECL, MOS, and CMOS Logic Systems in Most Applications

Applications

- High Source Impedance Voltage Comparators
- Long Time Delay Circuits
- Square Wave Generators
- A/D Converters
- Window Comparators

Part Number Information

PART NUMBER	TEMP RANGE (°C)	PACKAGE	PKG. NO.
CA3290AE	-55 to 125	8 Ld PDIP	E8.3
CA3290E	-55 to 125	8 Ld PDIP	E8.3

Schematic Diagram

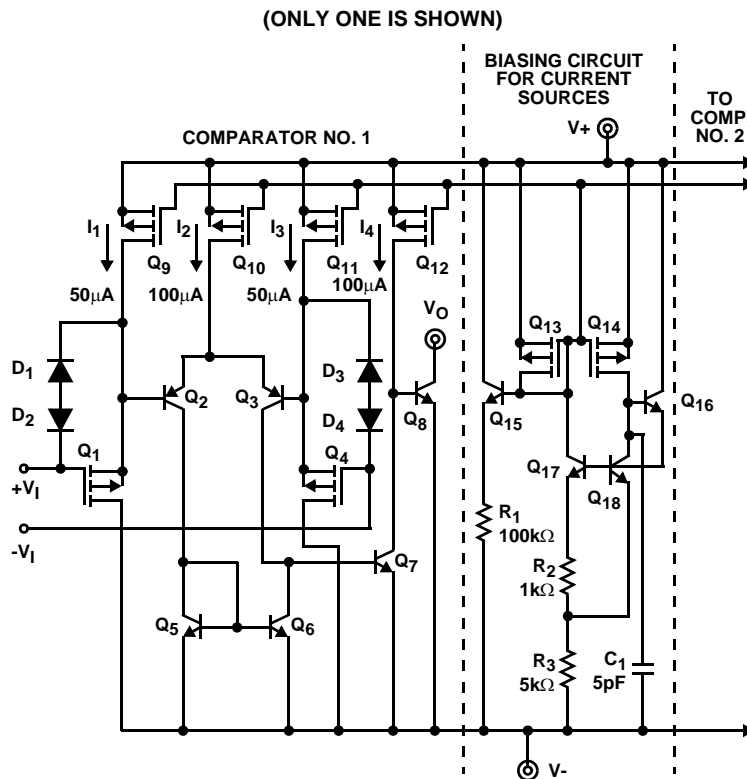

CA3290, CA3290A

Absolute Maximum Ratings

Supply Voltage	
Single Supply	+36V
Dual Supply	±18V
Differential Input Voltage	36V or [(V+ - V-) +5V] (whichever is less)
DC Input Voltage	V+ +5V to V- -5V
Output to V- Short Circuit Duration (Note 1)	Continuous
Input Current	1mA

Thermal Information

Thermal Resistance (Typical, Note 2)	θ_{JA} (°C/W)	θ_{JC} (°C/W)
PDIP Package	110	N/A
Maximum Junction Temperature (Plastic Package)	150°C	
Maximum Storage Temperature Range	-65°C to 150°C	
Maximum Lead Temperature (Soldering 10s)	300°C	

Operating Conditions

Temperature Range -55 to 125°C

CAUTION: Stresses above those listed in "Absolute Maximum Ratings" may cause permanent damage to the device. This is a stress only rating and operation of the device at these or any other conditions above those indicated in the operational sections of this specification is not implied.

NOTES:

- Short circuits from the output to V+ can cause excessive heating and eventual destruction of the device.
- θ_{JA} is measured with the component mounted on an evaluation PC board in free air.

Electrical Specifications V- = 0V, Unless Otherwise Specified

PARAMETER	SYMBOL	TEST CONDITIONS	TEMP (°C)	CA3290A			CA3290			UNITS
				MIN	TYP	MAX	MIN	TYP	MAX	
Input Offset Voltage	V_{IO}	$V_{CM} = V_O = 1.4V, V+ = 5V$	Full	-	4.5	-	-	8.5	-	mV
		$V_{CM} = V_O = 0V, V+ = +15V, V- = -15V$	Full	-	8.5	-	-	8.5	-	mV
		$V_{CM} = V_O = 1.4V, V+ = 5V$	25	-	4.0	10	-	7.5	20	mV
		$V_{CM} = V_O = 0V, V+ = +15V, V- = -15V$	25	-	4.0	10	-	7.5	20	mV
Temperature Coefficient of Input Offset Voltage	$\Delta V_{IO}/\Delta T$			-	8	-	-	8	-	$\mu V/^\circ C$
Input Offset Current	I_{IO}	$V_{CM} = 1.4V, V+ = 5V$	Full	-	2	28	-	2	32	nA
		$V_{CM} = 0V, V+ = +15V, V- = -15V$	Full	-	7	28	-	7	32	nA
		$V_{CM} = 1.4V, V+ = 5V$	25	-	2	25	-	2	30	pA
		$V_{CM} = 0V, V+ = +15V, V- = -15V$	25	-	7	25	-	7	30	pA
Input Current	I_I	$V_{CM} = 1.4V, V+ = 5V$	125	-	2.8	45	-	2.8	55	nA
		$V_{CM} = 0V, V+ = +15V, V- = -15V$	125	-	13	45	-	13	55	nA
		$V_{CM} = 1.4V, V+ = 5V$	25	-	3.5	40	-	3.5	50	pA
		$V_{CM} = 0V, V+ = +15V, V- = -15V$	25	-	12	40	-	12	50	pA
Supply Current	$I+$	$R_L = \infty, V+ = 5V$	-55	-	0.85	1.0	-	0.85	1.6	mA
		$R_L = \infty, V+ = 30V$	-55	-	1.62	3.0	-	1.62	3.5	mA
		$R_L = \infty, V+ = 5V$	25	-	0.8	1.4	-	0.8	1.4	mA
		$R_L = \infty, V+ = 30V$	25	-	1.35	3.0	-	1.35	3.0	mA
Voltage Gain	A_{OL}	$R_L = 15k\Omega, V+ = +15V, V- = -15V$	Full	-	150	-	-	150	-	V/mV
				-	103	-	-	103	-	dB
		$R_L = 15k\Omega, V+ = +15V, V- = -15V$	25	25	800	-	25	800	-	V/mV
				88	118	-	88	118	-	dB

CA3290, CA3290A

Electrical Specifications V- = 0V, Unless Otherwise Specified (Continued)

PARAMETER	SYMBOL	TEST CONDITIONS	TEMP (°C)	CA3290A			CA3290			UNITS
				MIN	TYP	MAX	MIN	TYP	MAX	
Saturation Voltage	V_{SAT}	$I_{SINK} = 4mA, V_+ = 5V, +V_I = 0V, -V_I = 1V$	125	-	0.22	0.7	-	0.22	0.7	V
		$I_{SINK} = 4mA, V_+ = 5V, +V_I = 0V, -V_I = 1V$	-55	-	0.1	-	-	0.1	-	V
		$I_{SINK} = 4mA, V_+ = 5V, +V_I = 0V, -V_I = 1V$	25	-	0.12	0.4	-	0.12	0.4	V
Output Leakage Current	I_{OL}	$V_+ = 15V$	Full	-	65	-	-	65	-	nA
		$V_+ = 36V$	Full	-	130	1k	-	130	1k	nA
		$V_+ = 15V$	25	-	100	-	-	100	-	pA
		$V_+ = 36V$	25	-	500	-	-	500	-	pA
Common Mode Input Voltage Range	V_{ICR}	$V_O = 1.4V, V_+ = 5V$	25	$V_+ - 3.5V$ V_-	$V_+ - 3.1V$ $V_- - 1.5$	-	$V_+ - 3.5V$ V_-	$V_+ - 3.1V$ $V_- - 1.5$	-	V
		$V_O = 0V, V_+ = +15V, V_- = -15V$	25	$V_+ - 3.8V$ V_-	$V_+ - 3.4V$ $V_- - 1.6$	-	$V_+ - 3.8V$ V_-	$V_+ - 3.4V$ $V_- - 1.6$	-	V
Common Mode Rejection Ratio	CMRR	$V_+ = +15V, V_- = -15V$	25	-	44	562	-	44	562	$\mu V/V$
		$V_+ = 5V$	25	-	100	562	-	100	562	$\mu V/V$
Power Supply Rejection Ratio	PSRR	$V_+ = +15V, V_- = -15V$	25	-	15	316	-	15	316	$\mu V/V$
Output Sink Current		$V_O = 1.4V, V_+ = 5V$	25	6	30	-	6	30	-	mA
Response Time Rising Edge	t_r	$R_L = 5.1k\Omega, V_+ = 15V$	25	-	1.2	-	-	1.2	-	μs
Response Time Falling Edge	t_f	$R_L = 5.1k\Omega, V_+ = 15V$	25	-	200	-	-	200	-	ns
Large Signal Response Time		$R_L = 5.1k\Omega, V_+ = 15V$	25	-	500	-	-	500	-	ns
		$R_L = 5.1k\Omega, V_+ = 5V$	25	-	400	-	-	400	-	ns

Test Circuits and Waveforms

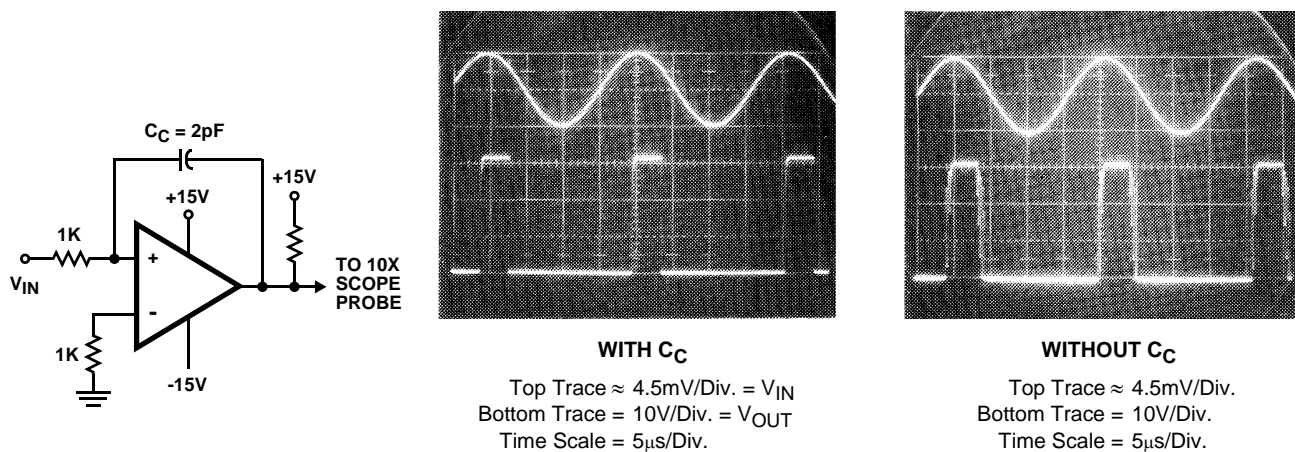

FIGURE 1. PARASITIC OSCILLATIONS TEST CIRCUIT AND WAVEFORMS

Test Circuits and Waveforms

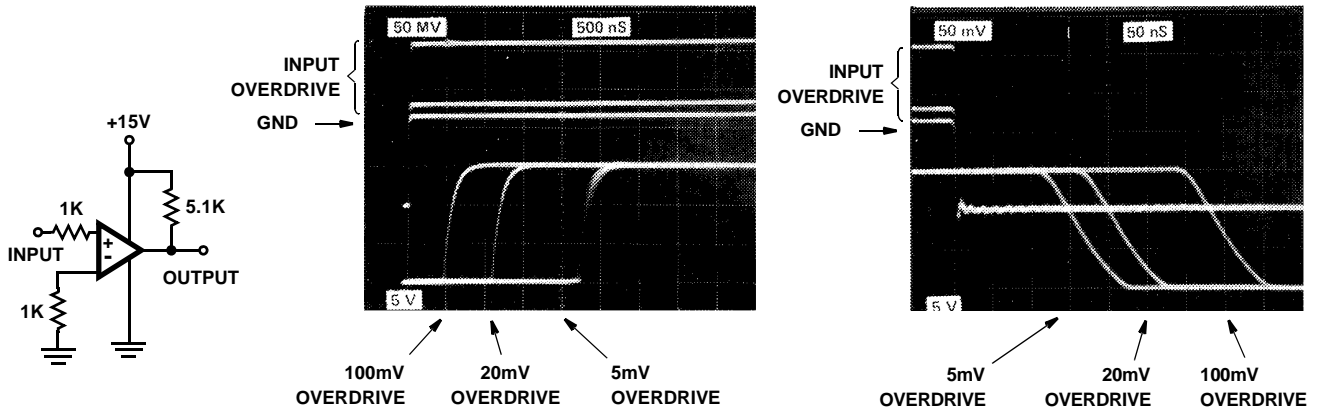

FIGURE 2. NON-INVERTING COMPARATOR RESPONSE TIME TEST CIRCUIT AND WAVEFORMS

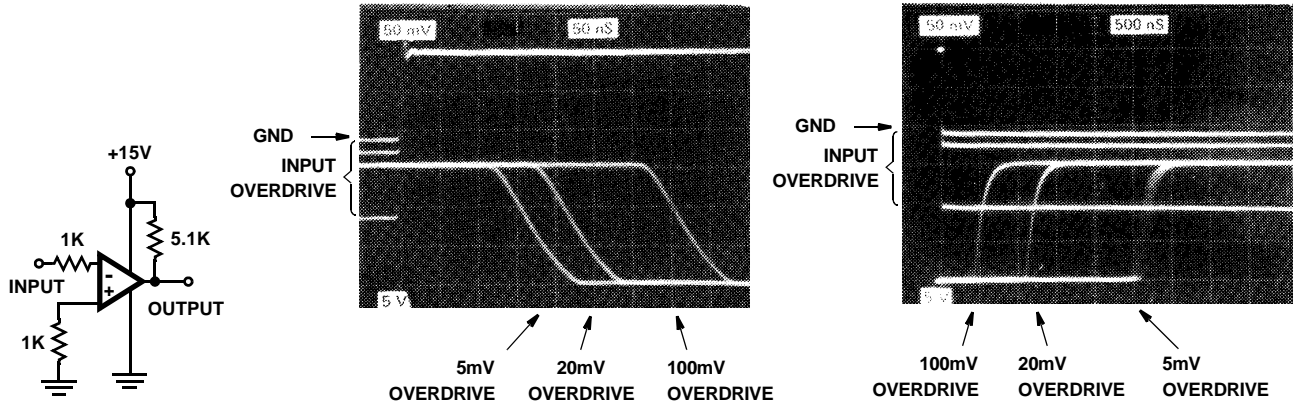

FIGURE 3. INVERTING COMPARATOR RESPONSE TIME TEST CIRCUIT AND WAVEFORMS

Circuit Description

The Basic Comparator

Figure 4 shows the basic circuit diagram for one of the two comparators in the CA3290. It is generically similar to the industry type "139" comparators, with PMOS transistors replacing PNP transistors as input stage elements. Transistors Q₁ through Q₄ comprise the differential input stage, with Q₅ and Q₆ serving as a mirror connected active load and differential-to-single-ended converter. The differential input at Q₁ and Q₄ is amplified so as to toggle Q₆ in accordance with the input signal polarity. For example, if +V_{IN} is greater than -V_{IN}, Q₁, Q₂, and current mirror transistors Q₅ and Q₆ will be turned off; Transistors Q₃, Q₄, and Q₇ will be turned on, causing Q₈ to be turned off. The output is pulled positive when a load resistor is connected between the output and V₊.

In essence, Q₁ and Q₄ function as source followers to drive Q₂ and Q₃, respectively, with zener diodes D₁ through D₄ providing gate oxide protection against input voltage

transients (e.g., static electricity). The current flow in Q₁ and Q₄ is established at approximately 50μA by constant current sources I₁ and I₃, respectively. Since Q₁ and Q₄ are operated with a constant current load, their gate-to-source voltage drops will be effectively constant as long as the input voltages are within the common-mode range.

As a result, the input offset voltage (V_{GS}(Q₁) + V_{BE}(Q₂) - V_{BE}(Q₃) - V_{GS}(Q₄)) will not be degraded when a large differential DC voltage is applied to the device for extended periods of time at high temperatures.

Additional voltage gain following the first stage is provided by transistors Q₇ and Q₈. The collector of Q₈ is open, offering the user a wide variety of options in applications. An additional discrete transistor can be added if it becomes necessary to boost the output sink current capability.

The detailed schematic diagram for one comparator and the common current source biasing is shown on the front page. PMOS transistors Q₉ through Q₁₂ are the current source

elements identified in Figure 4 as I_1 through I_4 , respectively. Their gate source potentials (V_{GS}) are supplied by a common bus from the biasing circuit shown in the right hand portion of the Schematic Diagram. The currents supplied by Q_{10} and Q_{12} are twice those supplied by Q_9 and Q_{11} . The transistor geometries are appropriately scaled to provide the requisite currents with common V_{GS} applied to Q_9 through Q_{12} .

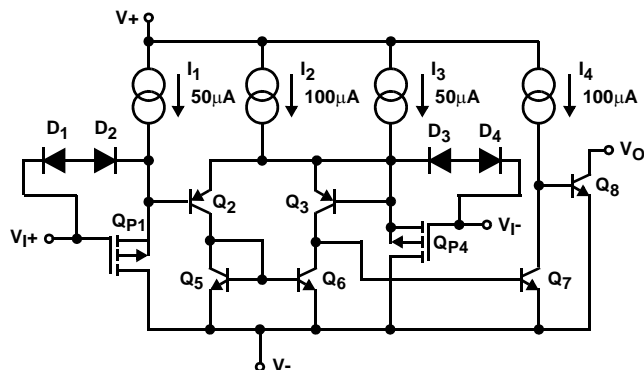

FIGURE 4. BASIC CIRCUIT DIAGRAM FOR ONE OF THE TWO COMPARATORS

Operating Considerations

Input Circuit

The use of MOS transistors in the input stage of the CA3290 series circuits provides the user with the following features for comparator applications:

1. Ultra high input impedance ($\approx 1.7T\Omega$);
2. The availability of common mode rejection for input signals at potentials below that of the negative power supply rail;
3. Retention of the in phase relationship of the input and output signals for input signals below the negative rail.

Although the CA3290 employs rugged bipolar (zener) diodes for protection of the input circuit, the input terminal currents should not exceed 1mA. Appropriate series connected limiting resistors should be used in circuits where greater current flows might exist, allowing the signal input voltage to be greater than the supply voltage without damaging the circuit.

Output Circuit

The output of the CA3290 is the open collector of an n-p-n transistor, a feature providing flexibility in a broad range of comparator applications. An output ORing function can be implemented by parallel connection of the open collectors. An output pull-up resistor can be connected to a power supply having a voltage range within the rating of the particular CA3290 in use; the magnitude of this voltage may be set at a value which is independent of that applied to the $V+$ terminal of the CA3290.

Parasitic Oscillations

The ideal comparator has, among other features, ultra high input impedance, high gain, and wide bandwidth. These desirable characteristics may, however, produce parasitic

oscillations unless certain precautions are observed to minimize the stray capacitive coupling between the input and output terminals. Parasitic oscillations manifest themselves during the output voltage transition intervals as the comparator switches states. For high source impedances, stray capacitance can induce parasitic oscillations. The addition of a small amount (1mV to 10mV) of positive feedback (hysteresis) produces a faster transition, thereby reducing the likelihood of parasitic oscillations. Furthermore, if the input signal is a pulse waveform, with relatively rapid rise and fall times, parasitic tendencies are reduced.

When dual comparators, like the CA3290, are packaged in an 8 lead configuration, the output terminal of each comparator is adjacent to an input terminal. The lead-to-lead capacitance is approximately 1pF, which may be sufficient to cause undesirable feedback effects in certain applications. Circuit factors such as impedance levels, supply voltage, switching rate, etc., may increase the possibility of parasitic oscillations. To minimize this potential oscillatory condition, it is recommended that for source impedances greater than 1k Ω a capacitor (≥ 1 pF - 2pF) be connected between the appropriate input terminal and the output terminal. (See Figure 1.)

If either comparator is unused, its input terminals should also be tied to either the $V+$ or $V-$ supply rail.

Typical Applications

Light Controlled One-Shot Timer

In Figure 5 one comparator (A_1) of the CA3290 is used to sense a change in photo diode current. The other comparator (A_2) is configured as a one-shot timer and is triggered by the output of A_1 . The output of the circuit will switch to a low state for approximately 60 seconds after the light source to the photo diode has been interrupted. The circuit operates at normal room lighting levels. The sensitivity of the circuit may be adjusted by changing the values of R_1 and R_2 . The ratio of R_1 to R_2 should be

constant to insure constant reverse voltage bias on the photo diode.

the lower limit (V_L) but below the upper limit (V_U), as determined by the $R_1/R_2/R_3$ resistor divider.

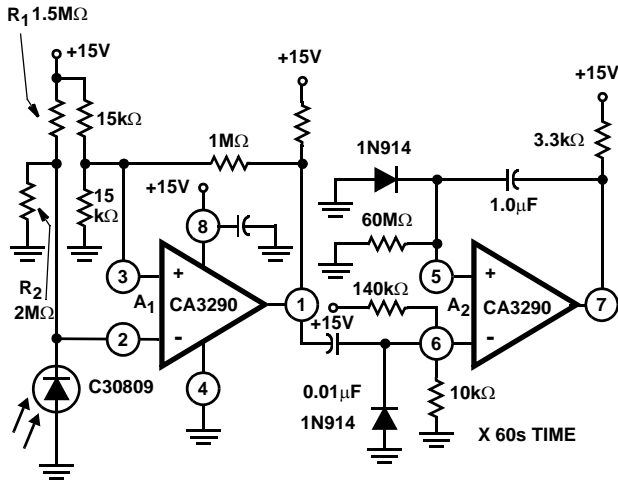

FIGURE 5. LIGHT CONTROLLED ONE-SHOT TIMER

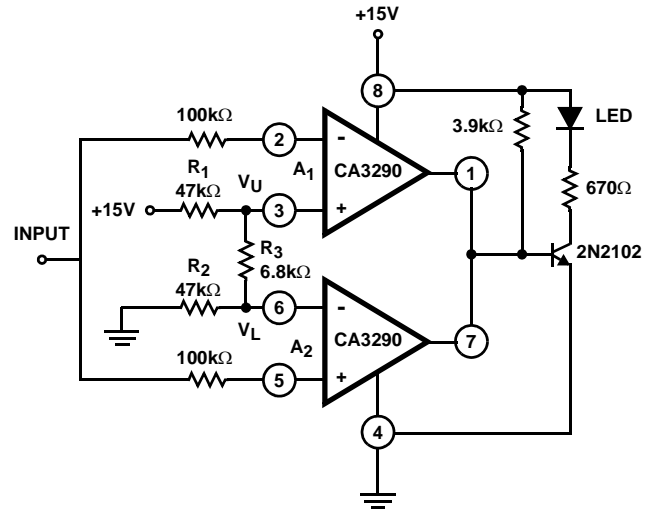
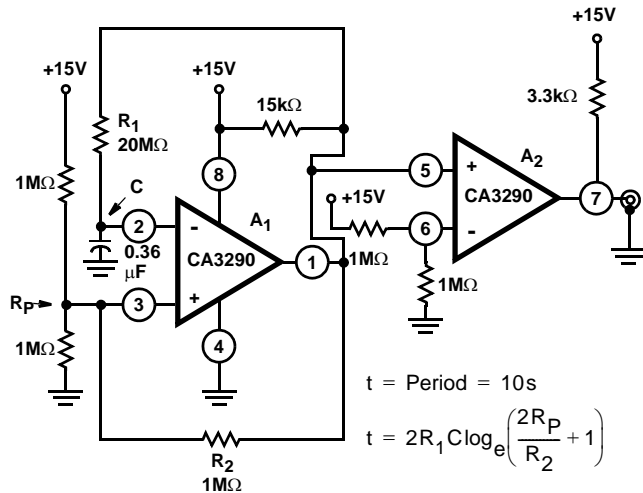

FIGURE 7. WINDOW COMPARATOR

Low-Frequency Multivibrator

In this application, one half of the CA3290 is used as a conventional multivibrator circuit. Because of the extremely high input impedance of this device, large values of timing resistor (R_1) may be used for long time delays with relatively small leakage timing capacitors. The second half of the CA3290 is used as an output buffer to insure that the multivibrator frequency will not be affected by output loading. R_P is the parallel combination of the two $1M\Omega$ resistors connected between +15V and GND.



$t = \text{Period} = 10s$
 $t = 2R_1 C \log_e \left(\frac{2R_P}{R_2} + 1 \right)$

FIGURE 6. LOW FREQUENCY MULTIVIBRATOR

Window Comparator

Both halves of the CA3290 can be used in a high input impedance window comparator as shown in Figure 7. The LED will be turned "on" whenever the input signal is above

Typical Performance Curves

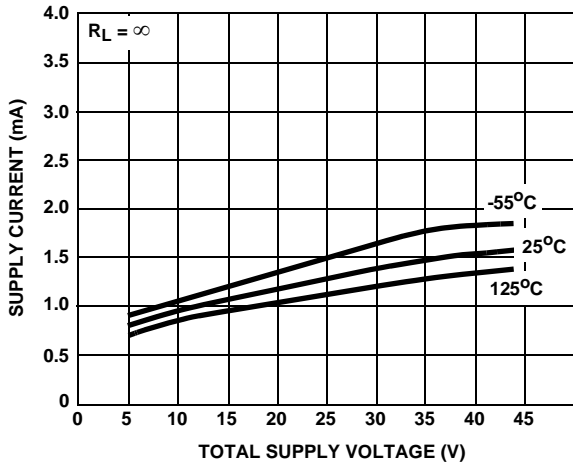

FIGURE 8. SUPPLY CURRENT vs SUPPLY VOLTAGE (BOTH AMPLIFIERS)

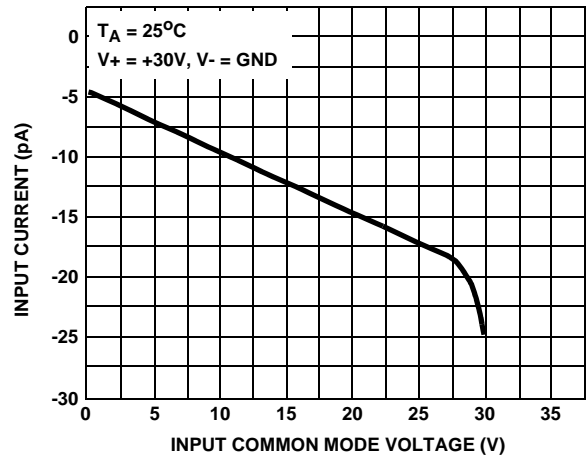

FIGURE 9. INPUT CURRENT vs INPUT COMMON MODE VOLTAGE

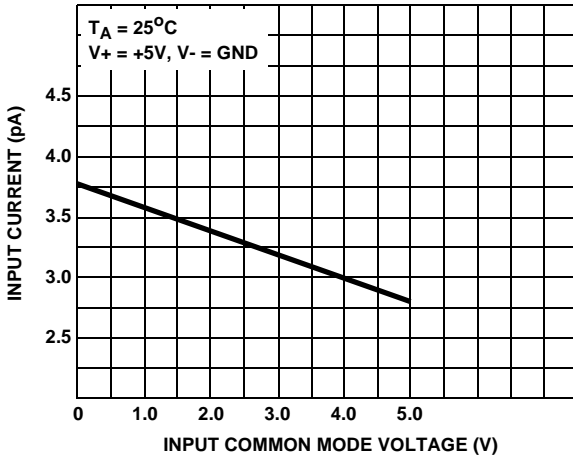

FIGURE 10. INPUT CURRENT vs INPUT COMMON MODE VOLTAGE

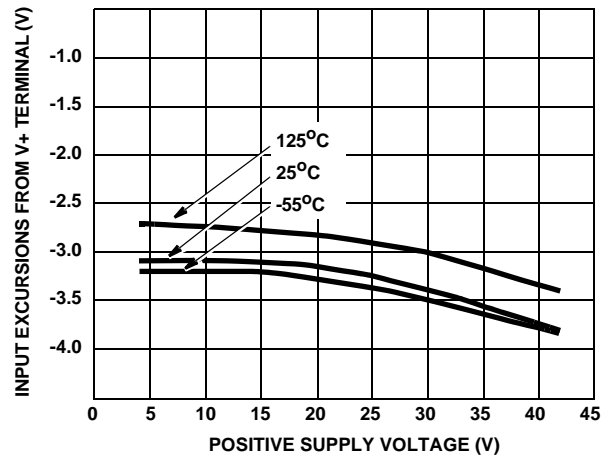

FIGURE 11. POSITIVE COMMON MODE INPUT VOLTAGE RANGE vs SUPPLY VOLTAGE

Typical Performance Curves (Continued)

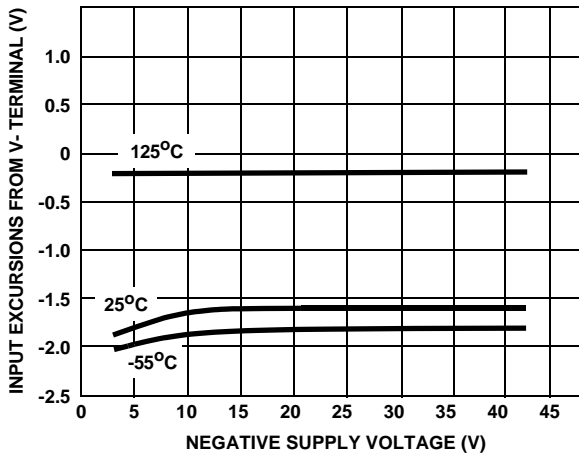

FIGURE 12. NEGATIVE COMMON MODE INPUT VOLTAGE RANGE vs SUPPLY VOLTAGE

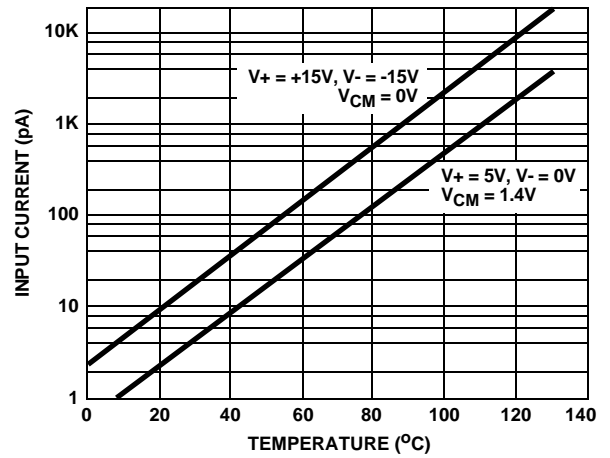

FIGURE 13. INPUT CURRENT vs TEMPERATURE

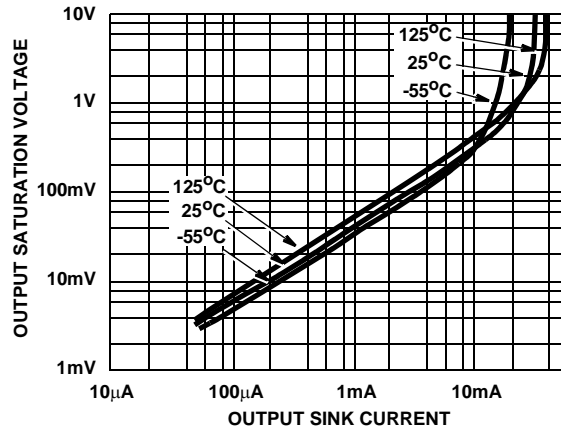
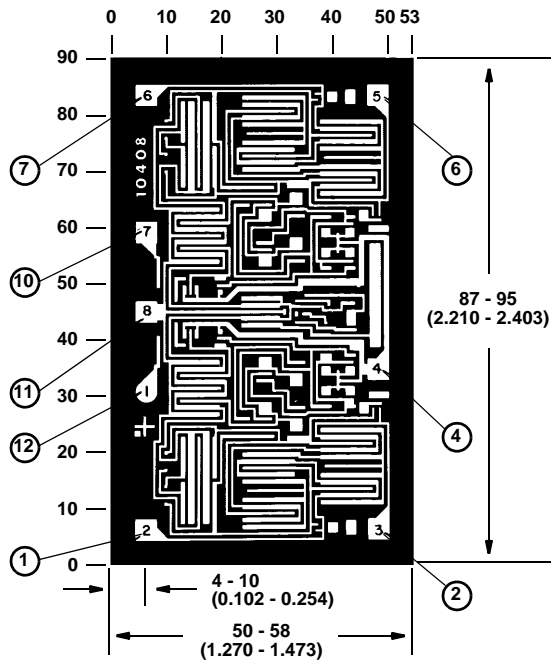

FIGURE 14. OUTPUT SATURATION VOLTAGE vs OUTPUT SINK CURRENT

Metallization Mask Layout



The photographs and dimensions of each chip represent a chip when it is part of the wafer. When the wafer is cut into chips, the cleavage angles are 57° instead of 90° with respect to the face of the chip. Therefore, the isolated chip is actually 7mils (0.17mm) larger in both dimensions.

Dimensions in parentheses are in millimeters and are derived from the basic inch dimensions as indicated. Grid graduations are in mils (10⁻³ inch)

NOTE: Numbers in pads are for 8 lead DIP and TO-5 Can and numbers outside of chip are for 14 lead DIP.

Dual-In-Line Plastic Packages (PDIP)

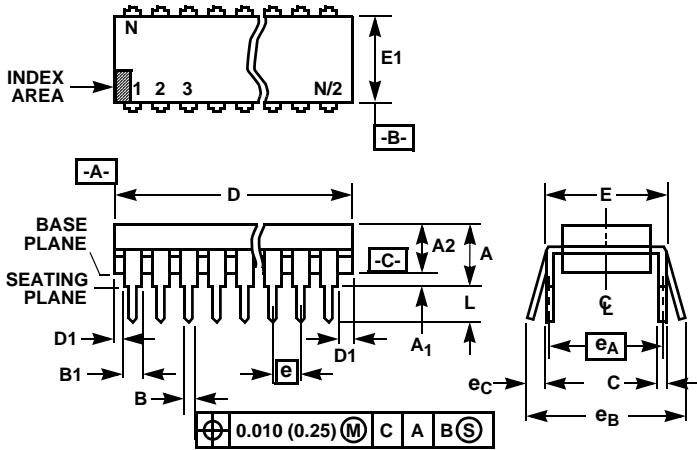

NOTES:

- Controlling Dimensions: INCH. In case of conflict between English and Metric dimensions, the inch dimensions control.
- Dimensioning and tolerancing per ANSI Y14.5M-1982.
- Symbols are defined in the "MO Series Symbol List" in Section 2.2 of Publication No. 95.
- Dimensions A, A1 and L are measured with the package seated in JEDEC seating plane gauge GS-3.
- D, D1, and E1 dimensions do not include mold flash or protrusions. Mold flash or protrusions shall not exceed 0.010 inch (0.25mm).
- E and e_A are measured with the leads constrained to be perpendicular to datum $-C-$.
- e_B and e_C are measured at the lead tips with the leads unconstrained. e_C must be zero or greater.
- B1 maximum dimensions do not include dambar protrusions. Dambar protrusions shall not exceed 0.010 inch (0.25mm).
- N is the maximum number of terminal positions.
- Corner leads (1, N, N/2 and N/2 + 1) for E8.3, E16.3, E18.3, E28.3, E42.6 will have a B1 dimension of 0.030 - 0.045 inch (0.76 - 1.14mm).

E8.3 (JEDEC MS-001-BA ISSUE D)
8 LEAD DUAL-IN-LINE PLASTIC PACKAGE

SYMBOL	INCHES		MILLIMETERS		NOTES
	MIN	MAX	MIN	MAX	
A	-	0.210	-	5.33	4
A1	0.015	-	0.39	-	4
A2	0.115	0.195	2.93	4.95	-
B	0.014	0.022	0.356	0.558	-
B1	0.045	0.070	1.15	1.77	8, 10
C	0.008	0.014	0.204	0.355	-
D	0.355	0.400	9.01	10.16	5
D1	0.005	-	0.13	-	5
E	0.300	0.325	7.62	8.25	6
E1	0.240	0.280	6.10	7.11	5
e	0.100 BSC		2.54 BSC		-
e_A	0.300 BSC		7.62 BSC		6
e_B	-	0.430	-	10.92	7
L	0.115	0.150	2.93	3.81	4
N	8		8		9

Rev. 0 12/93

All Intersil semiconductor products are manufactured, assembled and tested under ISO9000 quality systems certification.

Intersil semiconductor products are sold by description only. Intersil Corporation reserves the right to make changes in circuit design and/or specifications at any time without notice. Accordingly, the reader is cautioned to verify that data sheets are current before placing orders. Information furnished by Intersil is believed to be accurate and reliable. However, no responsibility is assumed by Intersil or its subsidiaries for its use; nor for any infringements of patents or other rights of third parties which may result from its use. No license is granted by implication or otherwise under any patent or patent rights of Intersil or its subsidiaries.

For information regarding Intersil Corporation and its products, see web site <http://www.intersil.com>