

# DS14C88

*DS14C88 Quad CMOS Line Driver*



Literature Number: SNLS080B

# DS14C88

## Quad CMOS Line Driver

### General Description

The DS14C88, pin-for-pin compatible to the DS1488/MC1488, is a quad line drivers designed to interface data terminal equipment (DTE) with data circuit-terminating equipment (DCE). This device translates standard TTL/CMOS logic levels to levels conforming to EIA-232-D and CCITT V.28 standards.

The device is fabricated in low threshold CMOS metal gate technology. The device provides very low power consumption compared to its bipolar equivalents: 500  $\mu$ A (DS14C88) versus 25 mA (DS1488).

The DS14C88 simplifies designs by eliminating the need for external slew rate control capacitors. Slew rate control in accordance with EIA-232D is provided on-chip, eliminating the output capacitors.

### Features

- Meets EIA-232D and CCITT V.28 standards
- LOW power consumption
- Wide power supply range:  $\pm 5V$  to  $\pm 12V$
- Available in SOIC package

### Connection Diagram

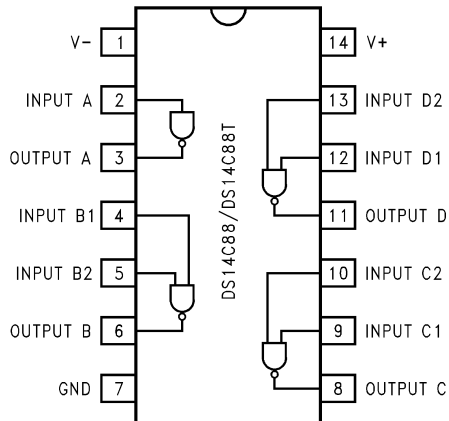

01110501

**Order Number DS14C88N, or DS14C88M**  
**See NS Package Number N14A or M14A**

**Absolute Maximum Ratings** (Note 1)

If Military/Aerospace specified devices are required, please contact the National Semiconductor Sales Office/Distributors for availability and specifications.

Supply Voltage	
V <sup>+</sup> Pin	+13V
V <sup>-</sup> Pin	-13V
Driver Input Voltage	(V <sup>+</sup> ) +0.3V to GND -0.3V
Driver Output Voltage	I(V <sup>+</sup> ) - V <sub>O</sub> ≤ 30V I(V <sup>-</sup> ) - V <sub>O</sub> ≤ 30V
Continuous Power Dissipation @+25°C (Note 2)	
N Package	1513 mW
M Package	1063 mW
Junction Temperature	+150°C

Lead Temperature	
(Soldering 4 seconds)	+260°C
Storage Temperature	
Range	-65°C to +150°C

This Product does not meet 2000V ESD rating. (Note 9)

**Recommended Operating Conditions**

	Min	Max	Units
V <sup>+</sup> Supply (GND = 0V)	+4.5	+12.6	V
V <sup>-</sup> Supply (GND = 0V)	-4.5	-12.6	V
Operating Free Air Temp. (T <sub>A</sub> )			
DS14C88	0	+75	°C

**Electrical Characteristics**

Over Recommended Operating Conditions, unless otherwise specified

Symbol	Parameter	Conditions	Min	Typ	Max	Units	
I <sub>IL</sub>	Maximum Low Input Current	V <sub>IN</sub> = GND			+10	µA	
I <sub>IH</sub>	Maximum High Input Current	V <sub>IN</sub> = V <sup>+</sup>	-10			µA	
V <sub>IL</sub>	Low Level Input Voltage	V <sup>+</sup> ≥ +7V, V <sup>-</sup> ≤ -7V	GND		0.8	V	
		V <sup>+</sup> < +7V, V <sup>-</sup> > -7V	GND		0.6	V	
V <sub>IH</sub>	High Level Input Voltage		2.0		V <sup>+</sup>	V	
V <sub>OL</sub>	Low Level Output Level	V <sub>IN</sub> = V <sub>IH</sub> R <sub>L</sub> = 3 kΩ or 7 kΩ	V <sup>+</sup> = 4.5V, V <sup>-</sup> = -4.5V		-4.0	-3.0	V
			V <sup>+</sup> = 9V, V <sup>-</sup> = 9V		-8.0	-6.5	V
			V <sup>+</sup> = 12V, V <sup>-</sup> = -12V		-10.5	-9.0	V
V <sub>OH</sub>	High Level Output Level	V <sub>IN</sub> = V <sub>IL</sub> R <sub>L</sub> = 3 kΩ or 7 kΩ	V <sup>+</sup> = 4.5V, V <sup>-</sup> = -4.5V	3.0	4.0		V
			V <sup>+</sup> = 9V, V <sup>-</sup> = -9V	6.5	8.0		V
			V <sup>+</sup> = 12V, V <sup>-</sup> = -12V	9.0	10.5		V
I <sub>OS+</sub>	High Level Output Short Circuit Current (Note 3)	V <sub>IN</sub> = 0.8V, V <sub>O</sub> = GND	V <sup>+</sup> = +12V, V <sup>-</sup> = -12V	-45			mA
I <sub>OS-</sub>	Low Level Output Short Circuit Current (Note 3)	V <sub>IN</sub> = 2.0V, V <sub>O</sub> = GND			+45		mA
R <sub>OUT</sub>	Output Resistance	V <sup>+</sup> = V <sup>-</sup> = GND = 0V -2V ≤ V <sub>O</sub> ≤ +2V (Note 4) (Figure 1)	300				Ω
I <sub>CC+</sub>	Positive Supply Current	V <sub>IN</sub> = V <sub>ILmax</sub> R <sub>L</sub> = OPEN	V <sup>+</sup> = 4.5V, V <sup>-</sup> = -4.5V		10		µA
			V <sup>+</sup> = 9V, V <sup>-</sup> = -9V		30		µA
			V <sup>+</sup> = 12V, V <sup>-</sup> = -12V		60		µA
		V <sub>IN</sub> = V <sub>IHmin</sub> R <sub>L</sub> = OPEN	V <sup>+</sup> = 4.5V, V <sup>-</sup> = -4.5V		50		µA
			V <sup>+</sup> = 9V, V <sup>-</sup> = -9V		300		µA
			V <sup>+</sup> = 12V, V <sup>-</sup> = -12V		500		µA
I <sub>CC-</sub>	Negative Supply Current	V <sub>IN</sub> = V <sub>ILmax</sub> R <sub>L</sub> = OPEN	V <sup>+</sup> = 4.5V, V <sup>-</sup> = -4.5V		-10		µA
			V <sup>+</sup> = 9V, V <sup>-</sup> = -9V		-10		µA
			V <sup>+</sup> = 12V, V <sup>-</sup> = -12V		-10		µA
		V <sub>IN</sub> = V <sub>IHmin</sub> R <sub>L</sub> = OPEN	V <sup>+</sup> = 4.5V, V <sup>-</sup> = -4.5V		-30		µA
			V <sup>+</sup> = 9V, V <sup>-</sup> = -9V		-30		µA
			V <sup>+</sup> = 12V, V <sup>-</sup> = -12V		-60		µA

## Switching Characteristics (Notes 5, 6)

Over Recommended Operating Conditions, unless otherwise specified (Figures 2, 3)

Symbol	Parameter	Conditions	Min	Typ	Max	Units
$t_{PLH}$	Propagation Delay Low to High	$V^+ = +4.5V, V^- = -4.5V$		1.5	6.0	$\mu s$
		$V^+ = +9.0V, V^- = -9.0V$		1.2	5.0	$\mu s$
		$V^+ = +12V, V^- = -12V$		1.2	4.0	$\mu s$
$t_{PHL}$	Propagation Delay High to Low	$V^+ = +4.5V, V^- = -4.5V$		1.5	6.0	$\mu s$
		$V^+ = +9.0V, V^- = -9.0V$		1.35	5.0	$\mu s$
		$V^+ = +12V, V^- = -12V$		1.3	4.0	$\mu s$
$t_r$	Rise Time (Note 7)		0.2	1.0	$\mu s$	
$t_f$	Fall Time (Note 7)		0.2	1.0	$\mu s$	
$t_{sk}$	Typical Propagation Delay Skew	$V^+ = +4.5V, V^- = -4.5V$		250		ns
		$V^+ = +9.0V, V^- = -9.0V$		200		ns
		$V^+ = +12V, V^- = -12V$		150		ns
$S_R$	Output Slew Rate (Note 7)	$R_L = 3\text{ k}\Omega$ to $7\text{ k}\Omega$			30	$V/\mu s$
		$C_L = 15\text{ pF}$ to $2500\text{ pF}$				

**Note 1:** "Absolute Maximum Ratings" are those values beyond which the safety of the device cannot be guaranteed. They are not meant to imply that the devices should be operated at these limits. The tables of "Electrical Characteristics" specify conditions for device operation.

**Note 2:** Derate N Package 12.1 mW/°C, and M Package 8.5 mW/°C above +25°C.

**Note 3:**  $I_{OS+}$  and  $I_{OS-}$  values are for one output at a time. If more than one output is shorted simultaneously, the device dissipation may be exceeded.

**Note 4:** Power supply ( $V^+$ ,  $V^-$ ) and GND pins are connected to ground for the Output Resistance Test ( $R_O$ ).

**Note 5:** AC input test waveforms for test purposes:  $t_r = t_f \leq 20\text{ ns}$ ,  $V_{IH} = 2V$ ,  $V_{IL} = 0.8V$  ( $0.6V$  at  $V^+ = 4.5V$ ,  $V^- = -4.5V$ )

**Note 6:** Input rise and fall times must not exceed  $5\ \mu s$ .

**Note 7:** The output slew rate, rise time, and fall time are measured from the  $+3.0V$  to the  $-3.0V$  level on the output waveform.

**Note 8:**  $C_L$  include jig and probe capacitances.

**Note 9:** ESD Rating (HBM,  $1.5\text{ k}\Omega$ ,  $100\text{ pF}$ )  $\geq 1.0\text{ kV}$ .

## Parameter Measure Information

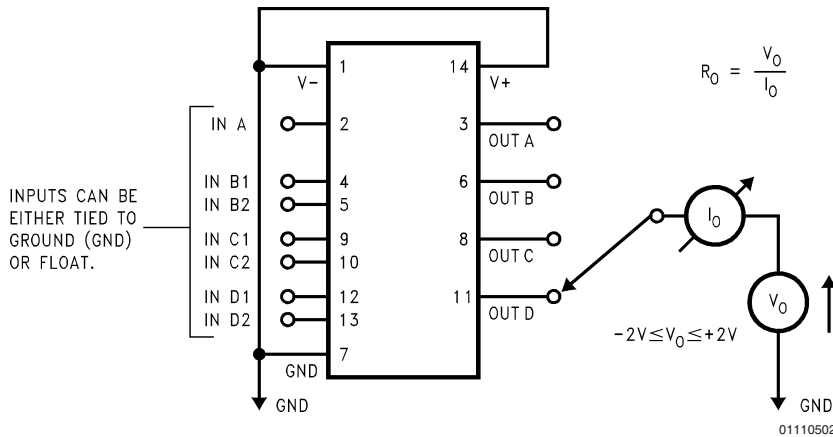

FIGURE 1. Output Resistance Test Circuit (Power-Off)

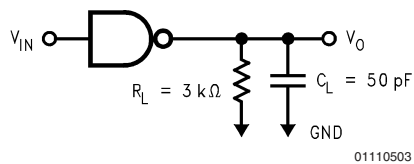
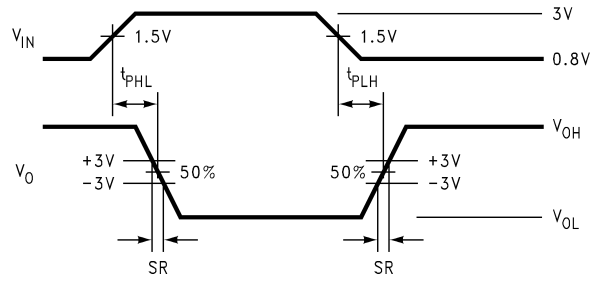

FIGURE 2. Driver Load Circuit (Note 8)

Parameter Measure Information (Continued)



01110504

FIGURE 3. Driver Switching Waveform

Typical Application Information

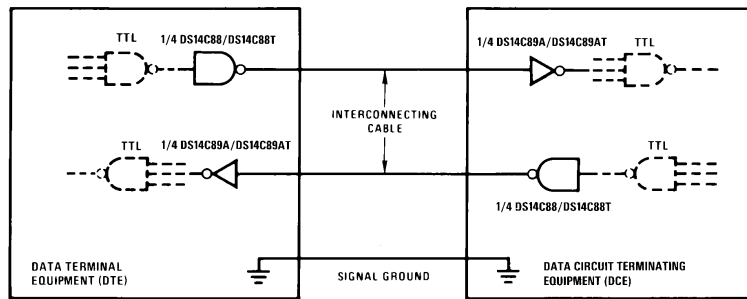

01110505

FIGURE 4. EIA-232D Data Transmission

**Physical Dimensions** inches (millimeters)

unless otherwise noted

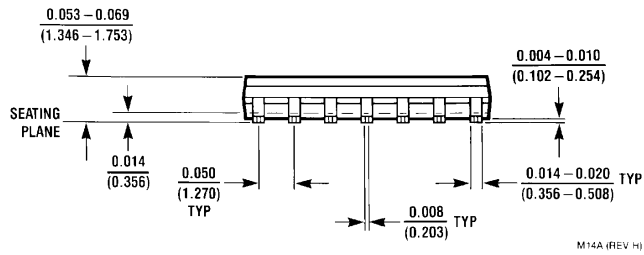
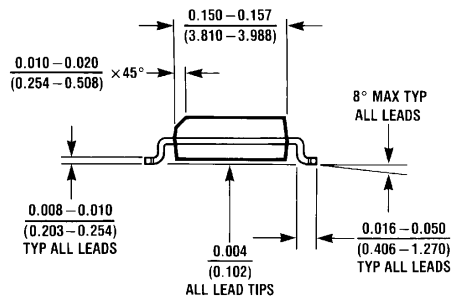
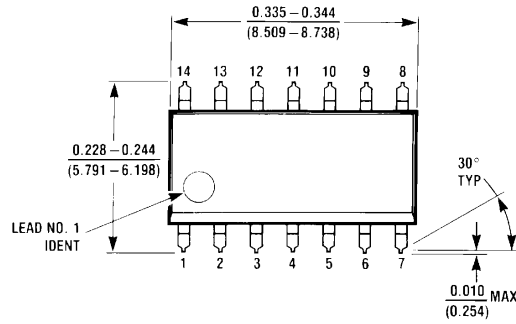

**Order Number DS14C88M or DS14C88TM**  
**NS Package Number M14A**

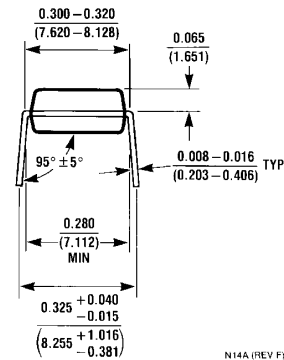
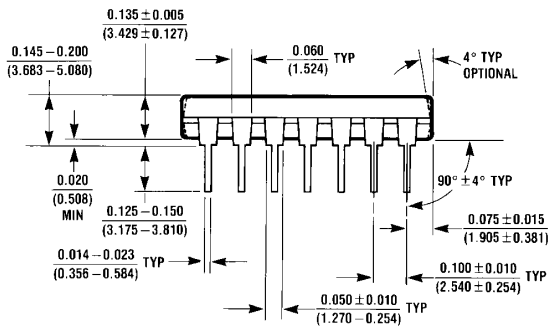
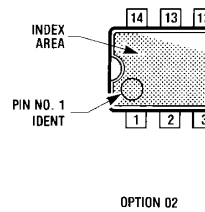
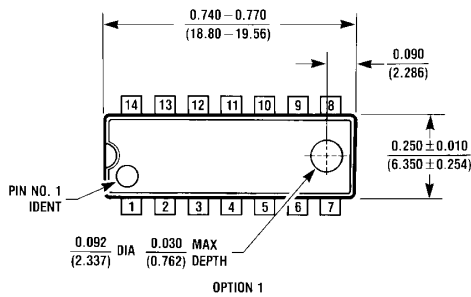

**Order Number DS14C88N or DS14C88TN**  
**NS Package Number N14A**

## Notes

### LIFE SUPPORT POLICY

NATIONAL'S PRODUCTS ARE NOT AUTHORIZED FOR USE AS CRITICAL COMPONENTS IN LIFE SUPPORT DEVICES OR SYSTEMS WITHOUT THE EXPRESS WRITTEN APPROVAL OF THE PRESIDENT AND GENERAL COUNSEL OF NATIONAL SEMICONDUCTOR CORPORATION. As used herein:

- |  |   |
|--|---|
| <p>1. Life support devices or systems are devices or systems which, (a) are intended for surgical implant into the body, or (b) support or sustain life, and whose failure to perform when properly used in accordance with instructions for use provided in the labeling, can be reasonably expected to result in a significant injury to the user.</p> | <p>2. A critical component is any component of a life support device or system whose failure to perform can be reasonably expected to cause the failure of the life support device or system, or to affect its safety or effectiveness.</p> |
|--|---|

---

### BANNED SUBSTANCE COMPLIANCE

National Semiconductor certifies that the products and packing materials meet the provisions of the Customer Products Stewardship Specification (CSP-9-111C2) and the Banned Substances and Materials of Interest Specification (CSP-9-111S2) and contain no "Banned Substances" as defined in CSP-9-111S2.

 <p><b>National Semiconductor</b> Americas Customer Support Center Email: <a href="mailto:new.feedback@nsc.com">new.feedback@nsc.com</a> Tel: 1-800-272-9959</p> <p><a href="http://www.national.com">www.national.com</a></p>	<p><b>National Semiconductor</b> Europe Customer Support Center Fax: +49 (0) 180-530 85 86 Email: <a href="mailto:europe.support@nsc.com">europe.support@nsc.com</a> Deutsch Tel: +49 (0) 69 9508 6208 English Tel: +44 (0) 870 24 0 2171 Français Tel: +33 (0) 1 41 91 8790</p>	<p><b>National Semiconductor</b> Asia Pacific Customer Support Center Email: <a href="mailto:ap.support@nsc.com">ap.support@nsc.com</a></p>	<p><b>National Semiconductor</b> Japan Customer Support Center Fax: 81-3-5639-7507 Email: <a href="mailto:jpn.feedback@nsc.com">jpn.feedback@nsc.com</a> Tel: 81-3-5639-7560</p>
---	--	---	--

## IMPORTANT NOTICE

Texas Instruments Incorporated and its subsidiaries (TI) reserve the right to make corrections, modifications, enhancements, improvements, and other changes to its products and services at any time and to discontinue any product or service without notice. Customers should obtain the latest relevant information before placing orders and should verify that such information is current and complete. All products are sold subject to TI's terms and conditions of sale supplied at the time of order acknowledgment.

TI warrants performance of its hardware products to the specifications applicable at the time of sale in accordance with TI's standard warranty. Testing and other quality control techniques are used to the extent TI deems necessary to support this warranty. Except where mandated by government requirements, testing of all parameters of each product is not necessarily performed.

TI assumes no liability for applications assistance or customer product design. Customers are responsible for their products and applications using TI components. To minimize the risks associated with customer products and applications, customers should provide adequate design and operating safeguards.

TI does not warrant or represent that any license, either express or implied, is granted under any TI patent right, copyright, mask work right, or other TI intellectual property right relating to any combination, machine, or process in which TI products or services are used. Information published by TI regarding third-party products or services does not constitute a license from TI to use such products or services or a warranty or endorsement thereof. Use of such information may require a license from a third party under the patents or other intellectual property of the third party, or a license from TI under the patents or other intellectual property of TI.

Reproduction of TI information in TI data books or data sheets is permissible only if reproduction is without alteration and is accompanied by all associated warranties, conditions, limitations, and notices. Reproduction of this information with alteration is an unfair and deceptive business practice. TI is not responsible or liable for such altered documentation. Information of third parties may be subject to additional restrictions.

Resale of TI products or services with statements different from or beyond the parameters stated by TI for that product or service voids all express and any implied warranties for the associated TI product or service and is an unfair and deceptive business practice. TI is not responsible or liable for any such statements.

TI products are not authorized for use in safety-critical applications (such as life support) where a failure of the TI product would reasonably be expected to cause severe personal injury or death, unless officers of the parties have executed an agreement specifically governing such use. Buyers represent that they have all necessary expertise in the safety and regulatory ramifications of their applications, and acknowledge and agree that they are solely responsible for all legal, regulatory and safety-related requirements concerning their products and any use of TI products in such safety-critical applications, notwithstanding any applications-related information or support that may be provided by TI. Further, Buyers must fully indemnify TI and its representatives against any damages arising out of the use of TI products in such safety-critical applications.

TI products are neither designed nor intended for use in military/aerospace applications or environments unless the TI products are specifically designated by TI as military-grade or "enhanced plastic." Only products designated by TI as military-grade meet military specifications. Buyers acknowledge and agree that any such use of TI products which TI has not designated as military-grade is solely at the Buyer's risk, and that they are solely responsible for compliance with all legal and regulatory requirements in connection with such use.

TI products are neither designed nor intended for use in automotive applications or environments unless the specific TI products are designated by TI as compliant with ISO/TS 16949 requirements. Buyers acknowledge and agree that, if they use any non-designated products in automotive applications, TI will not be responsible for any failure to meet such requirements.

Following are URLs where you can obtain information on other Texas Instruments products and application solutions:

### Products

Audio	<a href="http://www.ti.com/audio">www.ti.com/audio</a>
Amplifiers	<a href="http://amplifier.ti.com">amplifier.ti.com</a>
Data Converters	<a href="http://dataconverter.ti.com">dataconverter.ti.com</a>
DLP® Products	<a href="http://www.dlp.com">www.dlp.com</a>
DSP	<a href="http://dsp.ti.com">dsp.ti.com</a>
Clocks and Timers	<a href="http://www.ti.com/clocks">www.ti.com/clocks</a>
Interface	<a href="http://interface.ti.com">interface.ti.com</a>
Logic	<a href="http://logic.ti.com">logic.ti.com</a>
Power Mgmt	<a href="http://power.ti.com">power.ti.com</a>
Microcontrollers	<a href="http://microcontroller.ti.com">microcontroller.ti.com</a>
RFID	<a href="http://www.ti-rfid.com">www.ti-rfid.com</a>
OMAP Mobile Processors	<a href="http://www.ti.com/omap">www.ti.com/omap</a>
Wireless Connectivity	<a href="http://www.ti.com/wirelessconnectivity">www.ti.com/wirelessconnectivity</a>

### Applications

Communications and Telecom	<a href="http://www.ti.com/communications">www.ti.com/communications</a>
Computers and Peripherals	<a href="http://www.ti.com/computers">www.ti.com/computers</a>
Consumer Electronics	<a href="http://www.ti.com/consumer-apps">www.ti.com/consumer-apps</a>
Energy and Lighting	<a href="http://www.ti.com/energy">www.ti.com/energy</a>
Industrial	<a href="http://www.ti.com/industrial">www.ti.com/industrial</a>
Medical	<a href="http://www.ti.com/medical">www.ti.com/medical</a>
Security	<a href="http://www.ti.com/security">www.ti.com/security</a>
Space, Avionics and Defense	<a href="http://www.ti.com/space-avionics-defense">www.ti.com/space-avionics-defense</a>
Transportation and Automotive	<a href="http://www.ti.com/automotive">www.ti.com/automotive</a>
Video and Imaging	<a href="http://www.ti.com/video">www.ti.com/video</a>

TI E2E Community Home Page

[e2e.ti.com](http://e2e.ti.com)

Mailing Address: Texas Instruments, Post Office Box 655303, Dallas, Texas 75265  
Copyright © 2011, Texas Instruments Incorporated