

# SN54AS867, SN54AS869 SN74ALS867A, SN74ALS869, SN74AS867, SN74AS869 SYNCHRONOUS 8-BIT UP/DOWN COUNTERS

SDAS115C – DECEMBER 1982 – REVISED JANUARY 1995

- Fully Programmable With Synchronous Counting and Loading
- SN74ALS867A and 'AS867 Have Asynchronous Clear; SN74ALS869 and 'AS869 Have Synchronous Clear
- Fully Independent Clock Circuit Simplifies Use
- Ripple-Carry Output for n-Bit Cascading
- Package Options Include Plastic Small-Outline (DW) Packages, Ceramic Chip Carriers (FK), and Standard Plastic (NT) and Ceramic (JT) 300-mil DIPs

## description

These synchronous, presettable, 8-bit up/down counters feature internal-carry look-ahead circuitry for cascading in high-speed counting applications. Synchronous operation is provided by having all flip-flops clocked simultaneously so that the outputs change coincidentally with each other when so instructed by the count-enable ( $\overline{\text{ENP}}$ ,  $\overline{\text{ENT}}$ ) inputs and internal gating. This mode of operation eliminates the output counting spikes normally associated with asynchronous (ripple-clock) counters. A buffered clock (CLK) input triggers the eight flip-flops on the rising (positive-going) edge of the clock waveform.

These counters are fully programmable; they may be preset to any number between 0 and 255. The load-input circuitry allows parallel loading of the cascaded counters. Because loading is synchronous, selecting the load mode disables the counter and causes the outputs to agree with the data inputs after the next clock pulse.

The carry look-ahead circuitry provides for cascading counters for n-bit synchronous applications without additional gating. Two count-enable ( $\overline{\text{ENP}}$  and  $\overline{\text{ENT}}$ ) inputs and a ripple-carry (RCO) output are instrumental in accomplishing this function. Both  $\overline{\text{ENP}}$  and  $\overline{\text{ENT}}$  must be low to count. The direction of the count is determined by the levels of the select (S0, S1) inputs as shown in the function table.  $\overline{\text{ENT}}$  is fed forward to enable RCO. RCO thus enabled produces a low-level pulse while the count is zero (all outputs low) counting down or 255 counting up (all outputs high). This low-level overflow-carry pulse can be used to enable successive cascaded stages. Transitions at  $\overline{\text{ENP}}$  and  $\overline{\text{ENT}}$  are allowed regardless of the level of CLK. All inputs are diode clamped to minimize transmission-line effects, thereby simplifying system design.

These counters feature a fully independent clock circuit. With the exception of the asynchronous clear on the SN74ALS867A and 'AS867, changes at S0 and S1 that modify the operating mode have no effect on the Q outputs until clocking occurs. For the 'AS867 and 'AS869, any time  $\overline{\text{ENP}}$  and/or  $\overline{\text{ENT}}$  is taken high, RCO either goes or remains high. For the SN74ALS867A and SN74ALS869, any time  $\overline{\text{ENT}}$  is taken high, RCO either goes or remains high. The function of the counter (whether enabled, disabled, loading, or counting) is dictated solely by the conditions meeting the stable setup and hold times.

SN54AS867, SN54AS869 . . . JT PACKAGE  
SN74ALS867A, SN74ALS869, SN74AS867,  
SN74AS869 . . . DW OR NT PACKAGE  
(TOP VIEW)

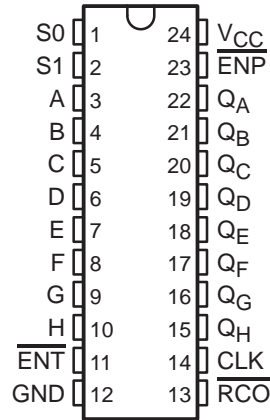

SN54AS867, SN54AS869 . . . FK PACKAGE  
(TOP VIEW)

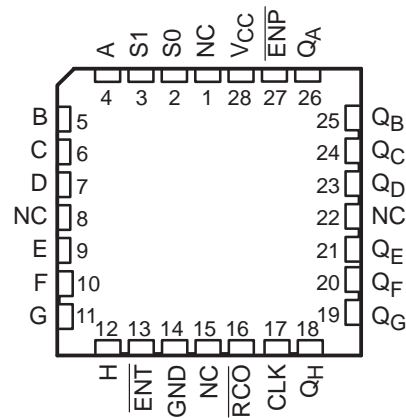

NC – No internal connection

**SN54AS867, SN54AS869**  
**SN74ALS867A, SN74ALS869, SN74AS867, SN74AS869**  
**SYNCHRONOUS 8-BIT UP/DOWN COUNTERS**

SDAS115C – DECEMBER 1982 – REVISED JANUARY 1995

---

**description (continued)**

The SN54AS867 and SN54AS869 are characterized for operation over the full military temperature range of  $-55^{\circ}\text{C}$  to  $125^{\circ}\text{C}$ . The SN74ALS867A, SN74ALS869, SN74AS867, and SN74AS869 are characterized for operation from  $0^{\circ}\text{C}$  to  $70^{\circ}\text{C}$ .

**FUNCTION TABLE**

<b>S1</b>	<b>S0</b>	<b>FUNCTION</b>
L	L	Clear
L	H	Count down
H	L	Load
H	H	Count up

SN54AS867, SN54AS869  
 SN74ALS867A, SN74ALS869, SN74AS867, SN74AS869  
**SYNCHRONOUS 8-BIT UP/DOWN COUNTERS**

SDAS115C – DECEMBER 1982 – REVISED JANUARY 1995

logic symbols†

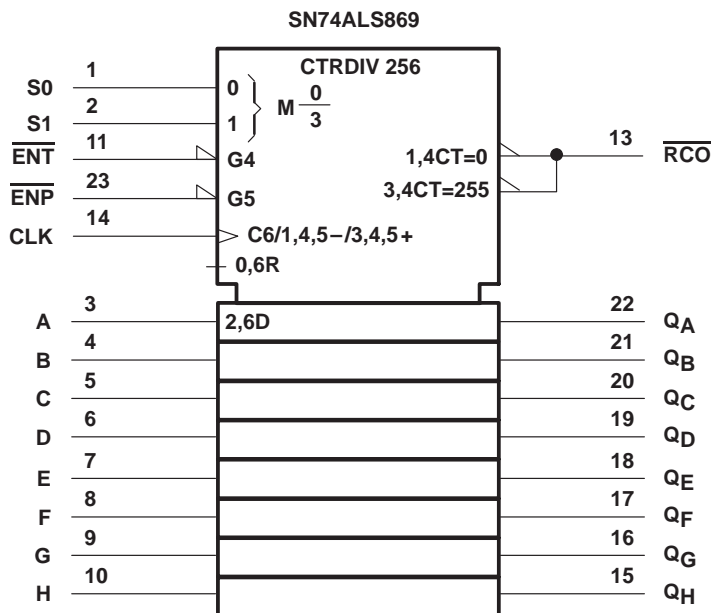
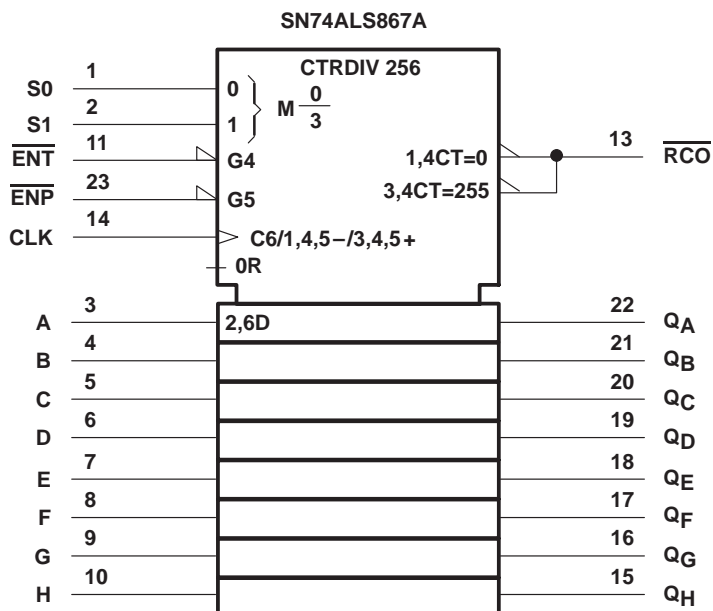

† These symbols are in accordance with ANSI/IEEE Std 91-1984 and IEC Publication 617-12.  
 Pin numbers shown are for the DW, JT, and NT packages.

SN54AS867, SN54AS869  
 SN74ALS867A, SN74ALS869, SN74AS867, SN74AS869  
 SYNCHRONOUS 8-BIT UP/DOWN COUNTERS

SDAS115C – DECEMBER 1982 – REVISED JANUARY 1995

logic symbols (continued)†

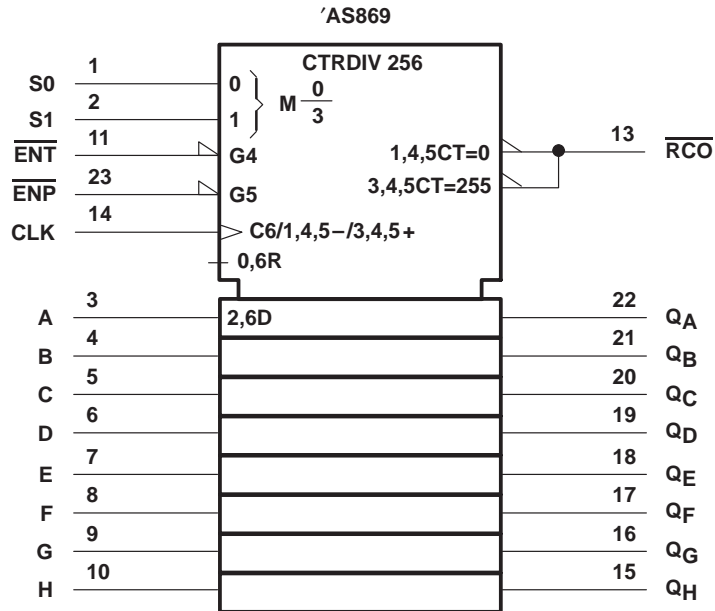
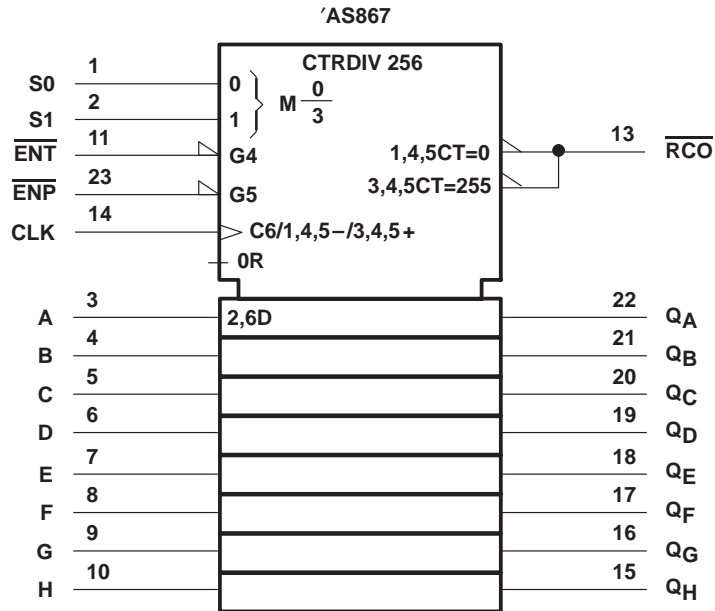

† These symbols are in accordance with ANSI/IEEE Std 91-1984 and IEC Publication 617-12. Pin numbers shown are for the DW, JT, and NT packages.

SN54AS867, SN54AS869  
 SN74ALS867A, SN74ALS869, SN74AS867, SN74AS869  
 SYNCHRONOUS 8-BIT UP/DOWN COUNTERS

SDAS115C - DECEMBER 1982 - REVISED JANUARY 1995

logic diagram (positive logic)

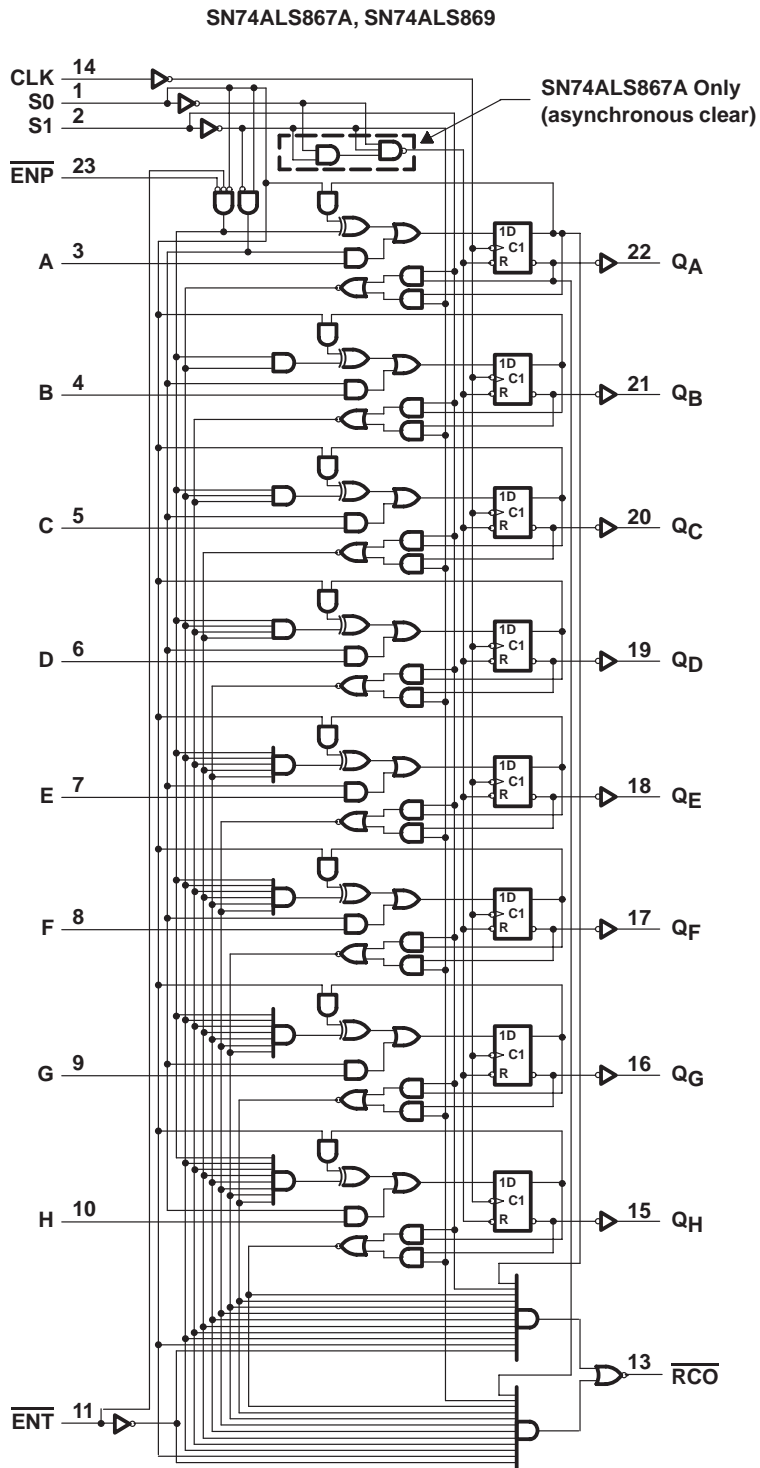

Pin numbers shown are for the DW, JT, and NT packages.



**SN54AS867, SN54AS869**  
**SN74ALS867A, SN74ALS869, SN74AS867, SN74AS869**  
**SYNCHRONOUS 8-BIT UP/DOWN COUNTERS**

SDAS115C – DECEMBER 1982 – REVISED JANUARY 1995

**logic diagram (positive logic)**

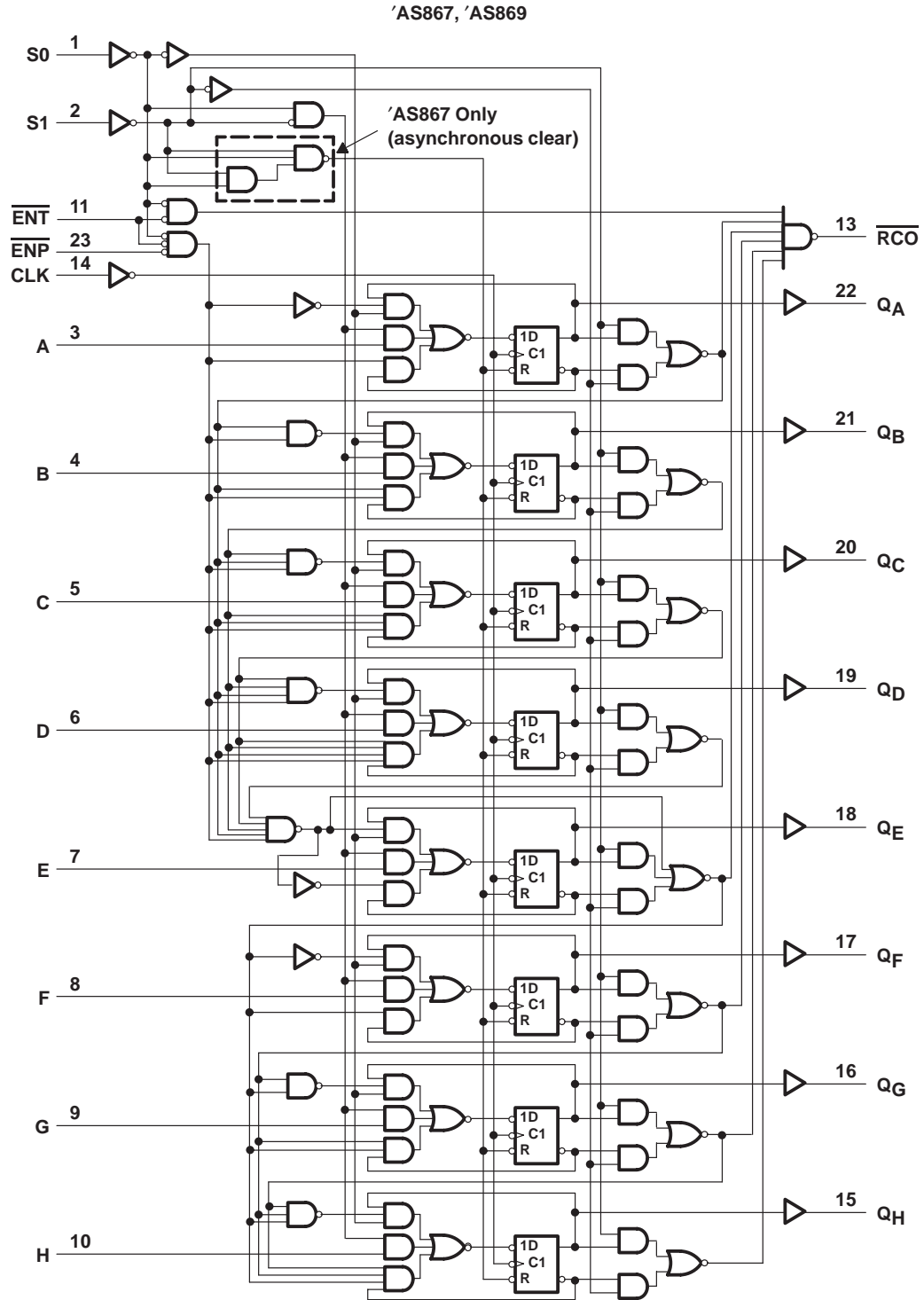

Pin numbers shown are for the DW, JT, and NT packages.



POST OFFICE BOX 655303 • DALLAS, TEXAS 75265

**typical clear, preset, count, and inhibit sequences**

The following sequence is illustrated below:

1. Clear outputs to zero (SN74ALS867A and 'AS867 are asynchronous;  
 SN74ALS869 and 'AS869 are synchronous.)
2. Preset to binary 252
3. Count up to 253, 254, 255, 0, 1, and 2
4. Count down to 1, 0, 255, 254, 253, and 252
5. Inhibit

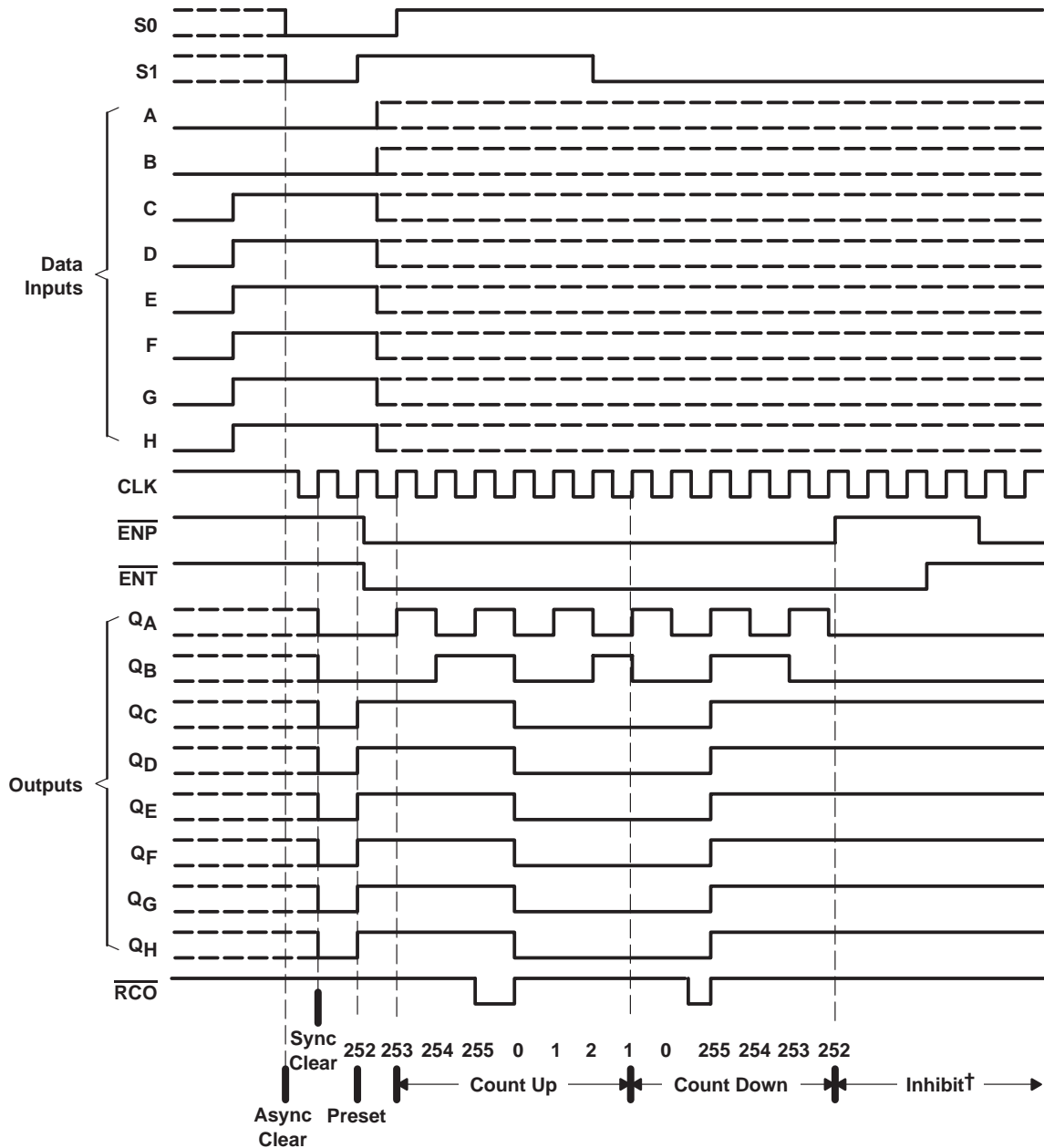

† ENT and ENP both must be low for counting to occur.

**SN54AS867, SN54AS869**  
**SN74ALS867A, SN74ALS869, SN74AS867, SN74AS869**  
**SYNCHRONOUS 8-BIT UP/DOWN COUNTERS**

SDAS115C – DECEMBER 1982 – REVISED JANUARY 1995

**absolute maximum ratings over operating free-air temperature range (unless otherwise noted)†**

Supply voltage, $V_{CC}$	7 V
Input voltage, $V_I$	7 V
Operating free-air temperature range, $T_A$ : SN74ALS867A	0°C to 70°C
Storage temperature range	-65°C to 150°C

† Stresses beyond those listed under “absolute maximum ratings” may cause permanent damage to the device. These are stress ratings only, and functional operation of the device at these or any other conditions beyond those indicated under “recommended operating conditions” is not implied. Exposure to absolute-maximum-rated conditions for extended periods may affect device reliability.

**recommended operating conditions**

		SN74ALS867A			UNIT
		MIN	NOM	MAX	
$V_{CC}$	Supply voltage	4.5	5	5.5	V
$V_{IH}$	High-level input voltage	2			V
$V_{IL}$	Low-level input voltage			0.8	V
$I_{OH}$	High-level output current			-0.4	mA
$I_{OL}$	Low-level output current			8	mA
$f_{clock}$	Clock frequency	0		35	MHz
$t_{w(clock)}$	Pulse duration, CLK high or low	14			ns
$t_{w(clear)}$	Pulse duration of clear pulse, S0 and S1 low	10			ns
$t_{su}$	Setup time before CLK↑	Data inputs A–H	10		ns
		$\overline{ENP}$ or $\overline{ENT}$	15		
		S0 low and S1 high (load)	12		
		S0 high and S1 low (count down)	12		
		S0 and S1 high (count up)	12		
$t_h$	Hold time after CLK↑	S0 high after S1↑ or S1 high after S0↑	3		ns
		Data inputs A–H	0		
$T_A$	Operating free-air temperature	0		70	°C

**electrical characteristics over recommended operating free-air temperature range (unless otherwise noted)**

PARAMETER	TEST CONDITIONS	SN74ALS867A			UNIT
		MIN	TYP‡	MAX	
$V_{IK}$	$V_{CC} = 4.5 V$ , $I_I = -18 mA$			-1.2	V
$V_{OH}$	$V_{CC} = 4.5 V$ to $5.5 V$ , $I_{OH} = -0.4 mA$	$V_{CC} - 2$			V
$V_{OL}$	$V_{CC} = 4.5 V$	$I_{OL} = 4 mA$	0.25	0.4	V
		$I_{OL} = 8 mA$	0.35	0.5	
$I_I$	$V_{CC} = 5.5 V$ , $V_I = 7 V$			0.1	mA
$I_{IH}$	$V_{CC} = 5.5 V$ , $V_I = 2.7 V$			20	μA
$I_{IL}$	$V_{CC} = 5.5 V$ , $V_I = 0.4 V$			-0.2	mA
$I_{O§}$	$V_{CC} = 5.5 V$ , $V_O = 2.25 V$	-30		-112	mA
$I_{CC}$	$V_{CC} = 5.5 V$		28	45	mA

‡ All typical values are at  $V_{CC} = 5 V$ ,  $T_A = 25^\circ C$ .

§ The output conditions have been chosen to produce a current that closely approximates one half of the true short-circuit output current,  $I_{OS}$ .





SN54AS867, SN54AS869  
 SN74ALS867A, SN74ALS869, SN74AS867, SN74AS869  
**SYNCHRONOUS 8-BIT UP/DOWN COUNTERS**

SDAS115C – DECEMBER 1982 – REVISED JANUARY 1995

**switching characteristics (see Figure 1)**

PARAMETER	FROM (INPUT)	TO (OUTPUT)	V <sub>CC</sub> = 4.5 V to 5.5 V, C <sub>L</sub> = 50 pF, R <sub>L</sub> = 500 Ω, T <sub>A</sub> = MIN to MAX†		UNIT
			SN74ALS867A		
			MIN	MAX	
f <sub>max</sub>			35		MHz
t <sub>PLH</sub>	CLK	$\overline{\text{RCO}}$	4	14	ns
t <sub>PHL</sub>			4	14	
t <sub>PLH</sub>	CLK	Any Q	3	16	ns
t <sub>PHL</sub>			3	16	
t <sub>PLH</sub>	$\overline{\text{ENT}}$	$\overline{\text{RCO}}$	3	14	ns
t <sub>PHL</sub>			2	9	
t <sub>PHL</sub>	S0 or S1 (clear mode)	Any Q	8	26	ns
t <sub>PLH</sub>	S0 or S1 (count up/down)	$\overline{\text{RCO}}$	4	16	ns
t <sub>PHL</sub>			4	16	
t <sub>PLH</sub>	S0 or S1 (clear mode)	$\overline{\text{RCO}}$	4	16	ns

† For conditions shown as MIN or MAX, use the appropriate value specified under recommended operating conditions.

**SN54AS867, SN54AS869**  
**SN74ALS867A, SN74ALS869, SN74AS867, SN74AS869**  
**SYNCHRONOUS 8-BIT UP/DOWN COUNTERS**

SDAS115C – DECEMBER 1982 – REVISED JANUARY 1995

**absolute maximum ratings over operating free-air temperature range (unless otherwise noted)†**

Supply voltage, $V_{CC}$	7 V
Input voltage, $V_I$	7 V
Operating free-air temperature range, $T_A$ : SN74ALS869	0°C to 70°C
Storage temperature range	-65°C to 150°C

† Stresses beyond those listed under “absolute maximum ratings” may cause permanent damage to the device. These are stress ratings only, and functional operation of the device at these or any other conditions beyond those indicated under “recommended operating conditions” is not implied. Exposure to absolute-maximum-rated conditions for extended periods may affect device reliability.

**recommended operating conditions**

		SN74ALS869			UNIT
		MIN	NOM	MAX	
$V_{CC}$	Supply voltage	4.5	5	5.5	V
$V_{IH}$	High-level input voltage	2			V
$V_{IL}$	Low-level input voltage			0.8	V
$I_{OH}$	High-level output current			-0.4	mA
$I_{OL}$	Low-level output current			8	mA
$f_{clock}$	Clock frequency	0		35	MHz
$t_{w(clock)}$	Pulse duration, CLK high or low	14			ns
$t_{su}$	Setup time before CLK↑	Data inputs A–H	10		ns
		$\overline{ENP}$ or $\overline{ENT}$	15		
		S0 and S1 low (clear)	13		
		S0 low and S1 high (load)	13		
		S0 high and S1 low (count down)	13		
		S0 and S1 high (count up)	13		
$t_h$	Hold time after CLK↑	S0 high after S1↑ or S1 high after S0↑	3		ns
		Data inputs A–H	0		
$T_A$	Operating free-air temperature	0		70	°C

**electrical characteristics over recommended operating free-air temperature range (unless otherwise noted)**

PARAMETER	TEST CONDITIONS	SN74ALS869			UNIT
		MIN	TYP‡	MAX	
$V_{IK}$	$V_{CC} = 4.5 V$ , $I_I = -18 mA$			-1.2	V
$V_{OH}$	$V_{CC} = 4.5 V$ to $5.5 V$ , $I_{OH} = -0.4 mA$	$V_{CC} - 2$			V
$V_{OL}$	$V_{CC} = 4.5 V$	$I_{OL} = 4 mA$	0.25	0.4	V
		$I_{OL} = 8 mA$	0.35	0.5	
$I_I$	$V_{CC} = 5.5 V$ , $V_I = 7 V$			0.1	mA
$I_{IH}$	$V_{CC} = 5.5 V$ , $V_I = 2.7 V$			20	μA
$I_{IL}$	$V_{CC} = 5.5 V$ , $V_I = 0.4 V$			-0.2	mA
$I_{O}^{\S}$	$V_{CC} = 5.5 V$ , $V_O = 2.25 V$	-30		-112	mA
$I_{CC}$	$V_{CC} = 5.5 V$		28	45	mA

‡ All typical values are at  $V_{CC} = 5 V$ ,  $T_A = 25^\circ C$ .

§ The output conditions have been chosen to produce a current that closely approximates one half of the true short-circuit output current,  $I_{OS}$ .



SN54AS867, SN54AS869  
 SN74ALS867A, SN74ALS869, SN74AS867, SN74AS869  
**SYNCHRONOUS 8-BIT UP/DOWN COUNTERS**

SDAS115C – DECEMBER 1982 – REVISED JANUARY 1995

**switching characteristics (see Figure 1)**

PARAMETER	FROM (INPUT)	TO (OUTPUT)	V <sub>CC</sub> = 4.5 V to 5.5 V, C <sub>L</sub> = 50 pF, R <sub>L</sub> = 500 Ω, T <sub>A</sub> = MIN to MAX†		UNIT
			SN74ALS869		
			MIN	MAX	
f <sub>max</sub>			35		MHz
t <sub>PLH</sub>	CLK	$\overline{RCO}$	4	14	ns
t <sub>PHL</sub>			4	14	
t <sub>PLH</sub>	CLK	Any Q	3	16	ns
t <sub>PHL</sub>			3	16	
t <sub>PLH</sub>	$\overline{ENT}$	$\overline{RCO}$	3	14	ns
t <sub>PHL</sub>			2	9	
t <sub>PLH</sub>	S1 (count up/down)	$\overline{RCO}$	4	15	ns
t <sub>PHL</sub>			4	15	
t <sub>PLH</sub>	S0 (clear/load)	$\overline{RCO}$	4	16	ns
t <sub>PHL</sub>			4	12	

† For conditions shown as MIN or MAX, use the appropriate value specified under recommended operating conditions.

**SN54AS867, SN54AS869**  
**SN74ALS867A, SN74ALS869, SN74AS867, SN74AS869**  
**SYNCHRONOUS 8-BIT UP/DOWN COUNTERS**

SDAS115C – DECEMBER 1982 – REVISED JANUARY 1995

**absolute maximum ratings over operating free-air temperature range (unless otherwise noted)†**

Supply voltage, $V_{CC}$	7 V
Input voltage, $V_I$	7 V
Operating free-air temperature range, $T_A$ : SN54AS867	–55°C to 125°C
SN74AS867	0°C to 70°C
Storage temperature range	–65°C to 150°C

† Stresses beyond those listed under “absolute maximum ratings” may cause permanent damage to the device. These are stress ratings only, and functional operation of the device at these or any other conditions beyond those indicated under “recommended operating conditions” is not implied. Exposure to absolute-maximum-rated conditions for extended periods may affect device reliability.

**recommended operating conditions**

		SN54AS867			SN74AS867			UNIT
		MIN	NOM	MAX	MIN	NOM	MAX	
$V_{CC}$	Supply voltage	4.5	5	5.5	4.5	5	5.5	V
$V_{IH}$	High-level input voltage	2			2			V
$V_{IL}$	Low-level input voltage			0.8			0.8	V
$I_{OH}$	High-level output current			–2			–2	mA
$I_{OL}$	Low-level output current			20			20	mA
$f_{clock}^*$	Clock frequency	0		40	0		50	MHz
$t_{w(clock)}^*$	Pulse duration, CLK high or low	12.5			10			ns
$t_{w(clear)}^*$	Pulse duration of clear pulse, S0 and S1 low	12.5			10			ns
$t_{su}^*$	Setup time before CLK↑	Data inputs A–H	5		4			ns
		$\overline{ENP}$ or $\overline{ENT}$	9		8			
		S0 low and S1 high (load)	11		10			
		S0 and S1 low (clear)	11		10			
		S0 high and S1 low (count down)	42		40			
		S0 and S1 high (count up)	42		40			
$t_h^*$	Hold time after CLK↑			Data inputs A–H	0		0	ns
$t_{skew}^*$	Skew time between S0 and S1 (maximum to avoid inadvertent clear)			8			7	ns
$T_A$	Operating free-air temperature	–55		125	0		70	°C

\* On products compliant to MIL-STD-883, Class B, this parameter is based on characterization data but is not production tested.



SN54AS867, SN54AS869  
SN74ALS867A, SN74ALS869, SN74AS867, SN74AS869  
**SYNCHRONOUS 8-BIT UP/DOWN COUNTERS**

SDAS115C – DECEMBER 1982 – REVISED JANUARY 1995

**electrical characteristics over recommended operating free-air temperature range (unless otherwise noted)**

PARAMETER	TEST CONDITIONS	SN54AS867		SN74AS867		UNIT		
		MIN	TYP†	MAX	MIN		TYP†	MAX
$V_{IK}$	$V_{CC} = 4.5\text{ V}$ , $I_I = -18\text{ mA}$			-1.2		-1.2	V	
$V_{OH}$	$V_{CC} = 4.5\text{ V to }5.5\text{ V}$ , $I_{OH} = -2\text{ mA}$	$V_{CC} - 2$			$V_{CC} - 2$		V	
$V_{OL}$	$V_{CC} = 4.5\text{ V}$ $I_{OL} = 20\text{ mA}$ , $V_{IL}$ on $\overline{ENT} = 0.7\text{ V}$	0.34		0.5			V	
						0.34 0.5		
$I_I$	$V_{CC} = 5.5\text{ V}$ , $V_I = 7\text{ V}$			0.1		0.1	mA	
$I_{IH}$	$V_{CC} = 5.5\text{ V}$ , $V_I = 2.7\text{ V}$			40		40		$\mu\text{A}$
				20		20		
$I_{IL}$	$V_{CC} = 5.5\text{ V}$ , $V_I = 0.4\text{ V}$			-4		-4		mA
				-2		-2		
$I_{O\ddagger}$	$V_{CC} = 5.5\text{ V}$ , $V_O = 2.25\text{ V}$	-30		-112	-30	-112	mA	
$I_{CC}$	$V_{CC} = 5.5\text{ V}$		134	195		134 195	mA	

† All typical values are at  $V_{CC} = 5\text{ V}$ ,  $T_A = 25^\circ\text{C}$ .

‡ The output conditions have been chosen to produce a current that closely approximates one half of the true short-circuit output current,  $I_{OS}$ .

**switching characteristics (see Figure 1)**

PARAMETER	FROM (INPUT)	TO (OUTPUT)	$V_{CC} = 4.5\text{ V to }5.5\text{ V}$ , $C_L = 50\text{ pF}$ , $R_L = 500\ \Omega$ , $T_A = \text{MIN to MAX}\S$				UNIT
			SN54AS867		SN74AS867		
			MIN	MAX	MIN	MAX	
$f_{max}^*$			40		50		MHz
$t_{PLH}$	CLK	$\overline{RCO}$	5	31	5	22	ns
$t_{PHL}$			6	19	6	16	
$t_{PLH}$	CLK	Any Q	3	12	3	11	ns
$t_{PHL}$			4	16	4	15	
$t_{PLH}$	$\overline{ENT}$	$\overline{RCO}$	3	19	3	10	ns
$t_{PHL}$			5	21	5	17	
$t_{PLH}$	$\overline{ENP}$	$\overline{RCO}$	5	16	5	14	ns
$t_{PHL}$			5	21	5	17	
$t_{PHL}$	Clear (S0 or S1 low)	Any Q	7	23	7	21	ns

\* On products compliant to MIL-STD-883, Class B, this parameter is based on characterization data but is not production tested.

§ For conditions shown as MIN or MAX, use the appropriate value specified under recommended operating conditions.



**SN54AS867, SN54AS869**  
**SN74ALS867A, SN74ALS869, SN74AS867, SN74AS869**  
**SYNCHRONOUS 8-BIT UP/DOWN COUNTERS**

SDAS115C – DECEMBER 1982 – REVISED JANUARY 1995

**absolute maximum ratings over operating free-air temperature range (unless otherwise noted)†**

Supply voltage, $V_{CC}$	7 V
Input voltage, $V_I$	7 V
Operating free-air temperature range, $T_A$ : SN54AS869	–55°C to 125°C
SN74AS869	0°C to 70°C
Storage temperature range	–65°C to 150°C

† Stresses beyond those listed under “absolute maximum ratings” may cause permanent damage to the device. These are stress ratings only, and functional operation of the device at these or any other conditions beyond those indicated under “recommended operating conditions” is not implied. Exposure to absolute-maximum-rated conditions for extended periods may affect device reliability.

**recommended operating conditions**

		SN54AS869			SN74AS869			UNIT
		MIN	NOM	MAX	MIN	NOM	MAX	
$V_{CC}$	Supply voltage	4.5	5	5.5	4.5	5	5.5	V
$V_{IH}$	High-level input voltage	2			2			V
$V_{IL}$	Low-level input voltage			0.7			0.8	V
$I_{OH}$	High-level output current			–2			–2	mA
$I_{OL}$	Low-level output current			20			20	mA
$f_{clock}^*$	Clock frequency			40			45	MHz
$t_{w(clock)}^*$	Pulse duration, CLK high or low	12.5			11			ns
$t_{su}^*$	Setup time before CLK↑	Data inputs A–H	6		5			ns
		$\overline{ENP}$ or $\overline{ENT}$	10		9			
		S0 low and S1 high (load)	13		11			
		S0 and S1 low (clear)	13		11			
		S0 high and S1 low (count down)	52		50			
		S0 and S1 high (count up)	52		50			
$t_h^*$	Hold time after CLK↑			0			0	ns
$T_A$	Operating free-air temperature		–55	125		0	70	°C

\* On products compliant to MIL-STD-883, Class B, this parameter is based on characterization data but is not production tested.



SN54AS867, SN54AS869  
SN74ALS867A, SN74ALS869, SN74AS867, SN74AS869  
**SYNCHRONOUS 8-BIT UP/DOWN COUNTERS**

SDAS115C – DECEMBER 1982 – REVISED JANUARY 1995

**electrical characteristics over recommended operating free-air temperature range (unless otherwise noted)**

PARAMETER		TEST CONDITIONS	SN54AS869		SN74AS869		UNIT	
			MIN	TYP†	MAX	MIN		TYP†
V <sub>IK</sub>		V <sub>CC</sub> = 4.5 V, I <sub>I</sub> = -18 mA			-1.2			V
V <sub>OH</sub>		V <sub>CC</sub> = 4.5 V to 5.5 V, I <sub>OH</sub> = -2 mA			V <sub>CC</sub> - 2		V	
		V <sub>CC</sub> = 4.5 V, I <sub>OH</sub> = -2 mA	V <sub>CC</sub> - 2*					
V <sub>OL</sub>	$\overline{\text{RCO}}$	V <sub>CC</sub> = 4.5 V	I <sub>OL</sub> = 20 mA, V <sub>IL</sub> on $\overline{\text{ENT}}$ = 0.7 V	0.34	0.5			V
	Other outputs					0.34	0.5	
I <sub>I</sub>		V <sub>CC</sub> = 5.5 V, V <sub>I</sub> = 7 V			0.1	0.1		mA
I <sub>IH</sub>	$\overline{\text{ENT}}$	V <sub>CC</sub> = 5.5 V, V <sub>I</sub> = 2.7 V			40	40		μA
	Other inputs				20	20		
I <sub>IL</sub>	$\overline{\text{ENT}}$	V <sub>CC</sub> = 5.5 V, V <sub>I</sub> = 0.4 V			-4	-4		mA
	Other inputs				-2	-2		
I <sub>O</sub> ‡		V <sub>CC</sub> = 5.5 V, V <sub>O</sub> = 2.25 V	-30	-112	-30	-112		mA
I <sub>CC</sub>		V <sub>CC</sub> = 5.5 V	134	195	134	195		mA

† All typical values are at V<sub>CC</sub> = 5 V, T<sub>A</sub> = 25°C.

‡ The output conditions have been chosen to produce a current that closely approximates one half of the true short-circuit output current, I<sub>OS</sub>.

**switching characteristics (see Figure 1)**

PARAMETER	FROM (INPUT)	TO (OUTPUT)	V <sub>CC</sub> = 4.5 V to 5.5 V, C <sub>L</sub> = 50 pF, R <sub>L</sub> = 500 Ω, T <sub>A</sub> = MIN to MAX§				UNIT
			SN54AS869		SN74AS869		
			MIN	MAX	MIN	MAX	
f <sub>max</sub> *			40		45	MHz	
t <sub>PLH</sub>	CLK	$\overline{\text{RCO}}$	6	35	6	35	ns
t <sub>PHL</sub>			6	20	6	18	
t <sub>PLH</sub>	CLK	Any Q	3	12	3	11	ns
t <sub>PHL</sub>			4	16	4	15	
t <sub>PLH</sub>	$\overline{\text{ENT}}$	$\overline{\text{RCO}}$	3	25	3	15	ns
t <sub>PHL</sub>			6	21	6	17	
t <sub>PLH</sub>	$\overline{\text{ENP}}$	$\overline{\text{RCO}}$	5	27	5	19	ns
t <sub>PHL</sub>			6	21	6	18	

\* On products compliant to MIL-STD-883, Class B, this parameter is based on characterization data but is not production tested.

§ For conditions shown as MIN or MAX, use the appropriate value specified under recommended operating conditions.

SN54AS867, SN54AS869  
 SN74ALS867A, SN74ALS869, SN74AS867, SN74AS869  
 SYNCHRONOUS 8-BIT UP/DOWN COUNTERS

SDAS115C – DECEMBER 1982 – REVISED JANUARY 1995

PARAMETER MEASUREMENT INFORMATION  
 SERIES 54ALS/74ALS AND 54AS/74AS DEVICES

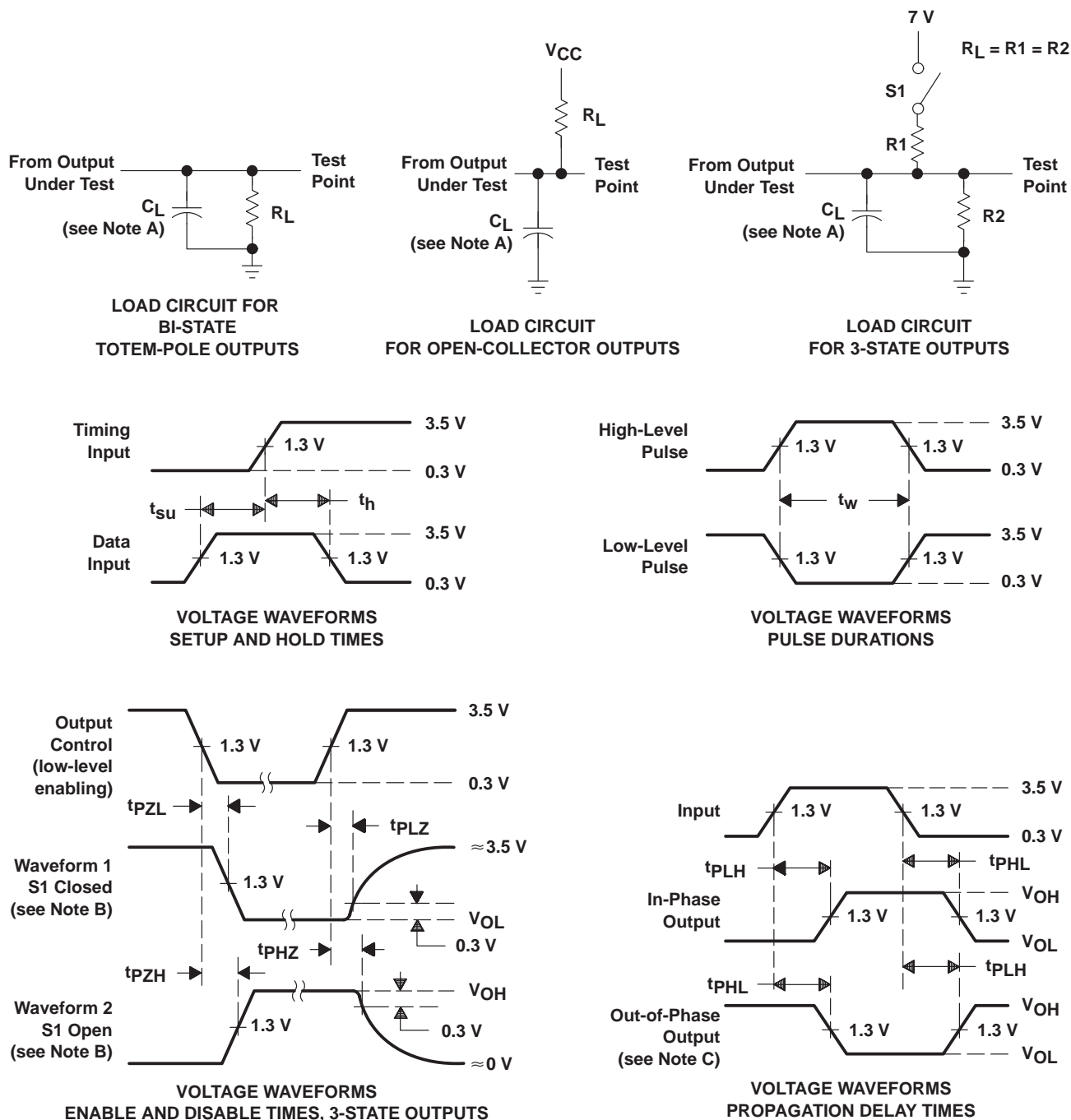

- NOTES: A.  $C_L$  includes probe and jig capacitance.  
 B. Waveform 1 is for an output with internal conditions such that the output is low except when disabled by the output control. Waveform 2 is for an output with internal conditions such that the output is high except when disabled by the output control.  
 C. When measuring propagation delay items of 3-state outputs, switch S1 is open.  
 D. All input pulses have the following characteristics:  $PRR \leq 1$  MHz,  $t_r = t_f = 2$  ns, duty cycle = 50%.  
 E. The outputs are measured one at a time with one transition per measurement.

Figure 1. Load Circuits and Voltage Waveforms



**PACKAGING INFORMATION**

Orderable Device	Status (1)	Package Type	Package Drawing	Pins	Package Qty	Eco Plan (2)	Lead/Ball Finish (6)	MSL Peak Temp (3)	Op Temp (°C)	Device Marking (4/5)	Samples
5962-8952601LA	ACTIVE	CDIP	JT	24	1	TBD	A42	N / A for Pkg Type	-55 to 125	5962-8952601LA SNJ54AS869JT	<a href="#">Samples</a>
5962-8966801LA	ACTIVE	CDIP	JT	24	1	TBD	A42	N / A for Pkg Type	-55 to 125	5962-8966801LA SNJ54AS867JT	<a href="#">Samples</a>
SN54AS867JT	ACTIVE	CDIP	JT	24	1	TBD	A42	N / A for Pkg Type	-55 to 125	SN54AS867JT	<a href="#">Samples</a>
SN54AS869JT	ACTIVE	CDIP	JT	24	1	TBD	A42	N / A for Pkg Type	-55 to 125	SN54AS869JT	<a href="#">Samples</a>
SN74ALS867ADW	ACTIVE	SOIC	DW	24	25	Green (RoHS & no Sb/Br)	CU NIPDAU	Level-1-260C-UNLIM	0 to 70	ALS867A	<a href="#">Samples</a>
SN74ALS869DW	ACTIVE	SOIC	DW	24	25	Green (RoHS & no Sb/Br)	CU NIPDAU	Level-1-260C-UNLIM	0 to 70	ALS869	<a href="#">Samples</a>
SN74ALS869DWE4	ACTIVE	SOIC	DW	24	25	Green (RoHS & no Sb/Br)	CU NIPDAU	Level-1-260C-UNLIM	0 to 70	ALS869	<a href="#">Samples</a>
SN74AS867DW	ACTIVE	SOIC	DW	24	25	Green (RoHS & no Sb/Br)	CU NIPDAU	Level-1-260C-UNLIM	0 to 70	AS867	<a href="#">Samples</a>
SN74AS867DWE4	ACTIVE	SOIC	DW	24	25	Green (RoHS & no Sb/Br)	CU NIPDAU	Level-1-260C-UNLIM	0 to 70	AS867	<a href="#">Samples</a>
SN74AS869DW	ACTIVE	SOIC	DW	24	25	Green (RoHS & no Sb/Br)	CU NIPDAU	Level-1-260C-UNLIM	0 to 70	AS869	<a href="#">Samples</a>
SNJ54AS867JT	ACTIVE	CDIP	JT	24	1	TBD	A42	N / A for Pkg Type	-55 to 125	5962-8966801LA SNJ54AS867JT	<a href="#">Samples</a>
SNJ54AS869JT	ACTIVE	CDIP	JT	24	1	TBD	A42	N / A for Pkg Type	-55 to 125	5962-8952601LA SNJ54AS869JT	<a href="#">Samples</a>

(1) The marketing status values are defined as follows:

**ACTIVE:** Product device recommended for new designs.

**LIFEBUY:** TI has announced that the device will be discontinued, and a lifetime-buy period is in effect.

**NRND:** Not recommended for new designs. Device is in production to support existing customers, but TI does not recommend using this part in a new design.

**PREVIEW:** Device has been announced but is not in production. Samples may or may not be available.

**OBSELETE:** TI has discontinued the production of the device.

(2) Eco Plan - The planned eco-friendly classification: Pb-Free (RoHS), Pb-Free (RoHS Exempt), or Green (RoHS & no Sb/Br) - please check <http://www.ti.com/productcontent> for the latest availability information and additional product content details.

**TBD:** The Pb-Free/Green conversion plan has not been defined.

---

**Pb-Free (RoHS):** TI's terms "Lead-Free" or "Pb-Free" mean semiconductor products that are compatible with the current RoHS requirements for all 6 substances, including the requirement that lead not exceed 0.1% by weight in homogeneous materials. Where designed to be soldered at high temperatures, TI Pb-Free products are suitable for use in specified lead-free processes.

**Pb-Free (RoHS Exempt):** This component has a RoHS exemption for either 1) lead-based flip-chip solder bumps used between the die and package, or 2) lead-based die adhesive used between the die and leadframe. The component is otherwise considered Pb-Free (RoHS compatible) as defined above.

**Green (RoHS & no Sb/Br):** TI defines "Green" to mean Pb-Free (RoHS compatible), and free of Bromine (Br) and Antimony (Sb) based flame retardants (Br or Sb do not exceed 0.1% by weight in homogeneous material)

<sup>(3)</sup> MSL, Peak Temp. - The Moisture Sensitivity Level rating according to the JEDEC industry standard classifications, and peak solder temperature.

<sup>(4)</sup> There may be additional marking, which relates to the logo, the lot trace code information, or the environmental category on the device.

<sup>(5)</sup> Multiple Device Markings will be inside parentheses. Only one Device Marking contained in parentheses and separated by a "~" will appear on a device. If a line is indented then it is a continuation of the previous line and the two combined represent the entire Device Marking for that device.

<sup>(6)</sup> Lead/Ball Finish - Orderable Devices may have multiple material finish options. Finish options are separated by a vertical ruled line. Lead/Ball Finish values may wrap to two lines if the finish value exceeds the maximum column width.

**Important Information and Disclaimer:** The information provided on this page represents TI's knowledge and belief as of the date that it is provided. TI bases its knowledge and belief on information provided by third parties, and makes no representation or warranty as to the accuracy of such information. Efforts are underway to better integrate information from third parties. TI has taken and continues to take reasonable steps to provide representative and accurate information but may not have conducted destructive testing or chemical analysis on incoming materials and chemicals. TI and TI suppliers consider certain information to be proprietary, and thus CAS numbers and other limited information may not be available for release.

In no event shall TI's liability arising out of such information exceed the total purchase price of the TI part(s) at issue in this document sold by TI to Customer on an annual basis.

**OTHER QUALIFIED VERSIONS OF SN54AS867, SN54AS869, SN74AS867, SN74AS869 :**

● Catalog: [SN74AS867](#), [SN74AS869](#)

● Military: [SN54AS867](#), [SN54AS869](#)

NOTE: Qualified Version Definitions:

● Catalog - TI's standard catalog product

● Military - QML certified for Military and Defense Applications

JT (R-GDIP-T\*\*)

CERAMIC DUAL-IN-LINE

24 LEADS SHOWN

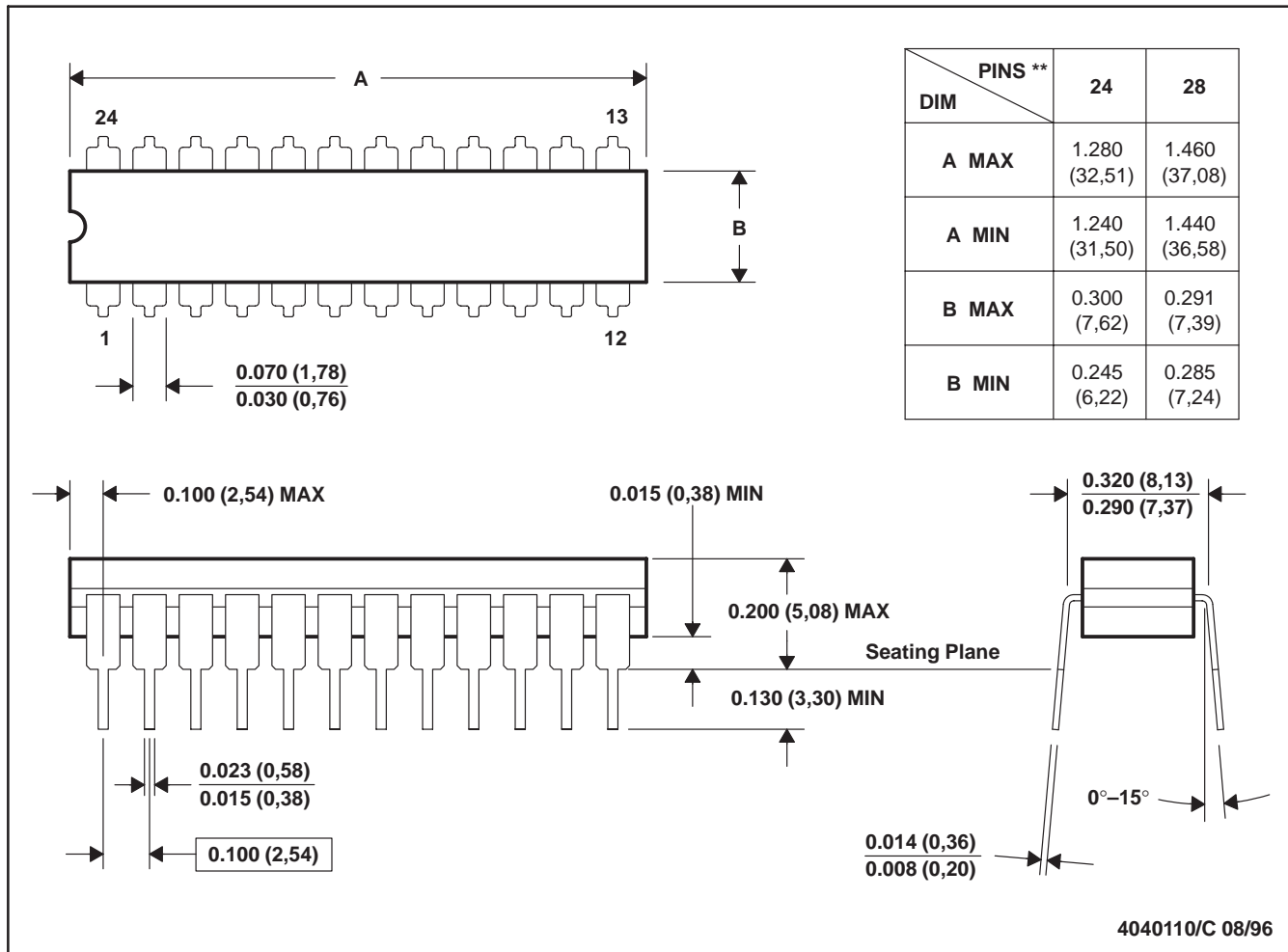

- NOTES: A. All linear dimensions are in inches (millimeters).  
 B. This drawing is subject to change without notice.  
 C. This package can be hermetically sealed with a ceramic lid using glass frit.  
 D. Index point is provided on cap for terminal identification.  
 E. Falls within MIL STD 1835 GDIP3-T24, GDIP4-T28, and JEDEC MO-058 AA, MO-058 AB

DW (R-PDSO-G24)

PLASTIC SMALL OUTLINE



- NOTES:
- A. All linear dimensions are in inches (millimeters). Dimensioning and tolerancing per ASME Y14.5M-1994.
  - B. This drawing is subject to change without notice.
  - C. Body dimensions do not include mold flash or protrusion not to exceed 0.006 (0,15).
  - D. Falls within JEDEC MS-013 variation AD.

## IMPORTANT NOTICE

Texas Instruments Incorporated (TI) reserves the right to make corrections, enhancements, improvements and other changes to its semiconductor products and services per JESD46, latest issue, and to discontinue any product or service per JESD48, latest issue. Buyers should obtain the latest relevant information before placing orders and should verify that such information is current and complete.

TI's published terms of sale for semiconductor products (<http://www.ti.com/sc/docs/stdterms.htm>) apply to the sale of packaged integrated circuit products that TI has qualified and released to market. Additional terms may apply to the use or sale of other types of TI products and services.

Reproduction of significant portions of TI information in TI data sheets is permissible only if reproduction is without alteration and is accompanied by all associated warranties, conditions, limitations, and notices. TI is not responsible or liable for such reproduced documentation. Information of third parties may be subject to additional restrictions. Resale of TI products or services with statements different from or beyond the parameters stated by TI for that product or service voids all express and any implied warranties for the associated TI product or service and is an unfair and deceptive business practice. TI is not responsible or liable for any such statements.

Buyers and others who are developing systems that incorporate TI products (collectively, "Designers") understand and agree that Designers remain responsible for using their independent analysis, evaluation and judgment in designing their applications and that Designers have full and exclusive responsibility to assure the safety of Designers' applications and compliance of their applications (and of all TI products used in or for Designers' applications) with all applicable regulations, laws and other applicable requirements. Designer represents that, with respect to their applications, Designer has all the necessary expertise to create and implement safeguards that (1) anticipate dangerous consequences of failures, (2) monitor failures and their consequences, and (3) lessen the likelihood of failures that might cause harm and take appropriate actions. Designer agrees that prior to using or distributing any applications that include TI products, Designer will thoroughly test such applications and the functionality of such TI products as used in such applications.

TI's provision of technical, application or other design advice, quality characterization, reliability data or other services or information, including, but not limited to, reference designs and materials relating to evaluation modules, (collectively, "TI Resources") are intended to assist designers who are developing applications that incorporate TI products; by downloading, accessing or using TI Resources in any way, Designer (individually or, if Designer is acting on behalf of a company, Designer's company) agrees to use any particular TI Resource solely for this purpose and subject to the terms of this Notice.

TI's provision of TI Resources does not expand or otherwise alter TI's applicable published warranties or warranty disclaimers for TI products, and no additional obligations or liabilities arise from TI providing such TI Resources. TI reserves the right to make corrections, enhancements, improvements and other changes to its TI Resources. TI has not conducted any testing other than that specifically described in the published documentation for a particular TI Resource.

Designer is authorized to use, copy and modify any individual TI Resource only in connection with the development of applications that include the TI product(s) identified in such TI Resource. NO OTHER LICENSE, EXPRESS OR IMPLIED, BY ESTOPPEL OR OTHERWISE TO ANY OTHER TI INTELLECTUAL PROPERTY RIGHT, AND NO LICENSE TO ANY TECHNOLOGY OR INTELLECTUAL PROPERTY RIGHT OF TI OR ANY THIRD PARTY IS GRANTED HEREIN, including but not limited to any patent right, copyright, mask work right, or other intellectual property right relating to any combination, machine, or process in which TI products or services are used. Information regarding or referencing third-party products or services does not constitute a license to use such products or services, or a warranty or endorsement thereof. Use of TI Resources may require a license from a third party under the patents or other intellectual property of the third party, or a license from TI under the patents or other intellectual property of TI.

TI RESOURCES ARE PROVIDED "AS IS" AND WITH ALL FAULTS. TI DISCLAIMS ALL OTHER WARRANTIES OR REPRESENTATIONS, EXPRESS OR IMPLIED, REGARDING RESOURCES OR USE THEREOF, INCLUDING BUT NOT LIMITED TO ACCURACY OR COMPLETENESS, TITLE, ANY EPIDEMIC FAILURE WARRANTY AND ANY IMPLIED WARRANTIES OF MERCHANTABILITY, FITNESS FOR A PARTICULAR PURPOSE, AND NON-INFRINGEMENT OF ANY THIRD PARTY INTELLECTUAL PROPERTY RIGHTS. TI SHALL NOT BE LIABLE FOR AND SHALL NOT DEFEND OR INDEMNIFY DESIGNER AGAINST ANY CLAIM, INCLUDING BUT NOT LIMITED TO ANY INFRINGEMENT CLAIM THAT RELATES TO OR IS BASED ON ANY COMBINATION OF PRODUCTS EVEN IF DESCRIBED IN TI RESOURCES OR OTHERWISE. IN NO EVENT SHALL TI BE LIABLE FOR ANY ACTUAL, DIRECT, SPECIAL, COLLATERAL, INDIRECT, PUNITIVE, INCIDENTAL, CONSEQUENTIAL OR EXEMPLARY DAMAGES IN CONNECTION WITH OR ARISING OUT OF TI RESOURCES OR USE THEREOF, AND REGARDLESS OF WHETHER TI HAS BEEN ADVISED OF THE POSSIBILITY OF SUCH DAMAGES.

Unless TI has explicitly designated an individual product as meeting the requirements of a particular industry standard (e.g., ISO/TS 16949 and ISO 26262), TI is not responsible for any failure to meet such industry standard requirements.

Where TI specifically promotes products as facilitating functional safety or as compliant with industry functional safety standards, such products are intended to help enable customers to design and create their own applications that meet applicable functional safety standards and requirements. Using products in an application does not by itself establish any safety features in the application. Designers must ensure compliance with safety-related requirements and standards applicable to their applications. Designer may not use any TI products in life-critical medical equipment unless authorized officers of the parties have executed a special contract specifically governing such use. Life-critical medical equipment is medical equipment where failure of such equipment would cause serious bodily injury or death (e.g., life support, pacemakers, defibrillators, heart pumps, neurostimulators, and implantables). Such equipment includes, without limitation, all medical devices identified by the U.S. Food and Drug Administration as Class III devices and equivalent classifications outside the U.S.

TI may expressly designate certain products as completing a particular qualification (e.g., Q100, Military Grade, or Enhanced Product). Designers agree that it has the necessary expertise to select the product with the appropriate qualification designation for their applications and that proper product selection is at Designers' own risk. Designers are solely responsible for compliance with all legal and regulatory requirements in connection with such selection.

Designer will fully indemnify TI and its representatives against any damages, costs, losses, and/or liabilities arising out of Designer's non-compliance with the terms and provisions of this Notice.